

**ASRock®**



**B550 PHANTOM GAMING 4/ac**  
**B550 PHANTOM GAMING 4**

User Manual

## Contact Information

If you need to contact ASRock or want to know more about ASRock, you're welcome to visit ASRock's website at <http://www.asrock.com>; or you may contact your dealer for further information. For technical questions, please submit a support request form at <https://event.asrock.com/tsd.asp>

### **ASRock Incorporation**

e-mail: [info@asrock.com.tw](mailto:info@asrock.com.tw)

### **ASRock EUROPE B.V.**

e-mail: [sales@asrock.nl](mailto:sales@asrock.nl)

### **ASRock America, Inc.**

e-mail: [sales@asrockamerica.com](mailto:sales@asrockamerica.com)



Scan the QR code to view more manuals and documents.

B550 Phantom Gaming 4/ac



Scan the QR code to view more manuals and documents.

B550 Phantom Gaming 4

# Contents

<b>Chapter 1 Introduction</b>	<b>1</b>
1.1 Package Contents	1
1.2 Specifications	2
1.3 Motherboard Layout	8
1.4 I/O Panel	12
1.5 WiFi-802.11ac Module and ASRock WiFi 2.4/5 GHz Antennas (For B550 Phantom Gaming 4/ac)	14
<b>Chapter 2 Installation</b>	<b>16</b>
2.1 Installing the CPU	17
2.2 Installing the CPU Fan and Heatsink	19
2.3 Installing Memory Modules (DIMM)	27
2.4 Expansion Slots (PCI Express Slots)	30
2.5 Jumpers Setup	31
2.6 Onboard Headers and Connectors	32
2.7 Post Status Checker	37
2.8 CrossFireX™ and Quad CrossFireX™ Operation Guide	38
2.8.1 Installing Two CrossFireX™-Ready Graphics Cards	38
2.8.2 Driver Installation and Setup	40
2.9 M.2_SSD (NGFF) Module Installation Guide (M2_1)	41
2.10 M.2 WiFi/BT Module Installation Guide (M2_2) (For B550 Phantom Gaming 4)	44
2.11 M.2_SSD (NGFF) Module Installation Guide (M2_3) (For B550 Phantom Gaming 4)	46

## **Chapter 3 Software and Utilities Operation 49**

3.1	Installing Drivers	49
3.2	ASRock Motherboard Utility (Phantom Gaming Tuning)	50
3.3	ASRock Live Update & APP Shop	53
3.3.1	UI Overview	53
3.3.2	Apps	54
3.3.3	BIOS & Drivers	57
3.3.4	Setting	58
3.4	Nahimic Audio	59
3.5	ASRock Polychrome SYNC	60

## **Chapter 4 UEFI SETUP UTILITY 63**

4.1	Introduction	63
4.1.1	UEFI Menu Bar	63
4.1.2	Navigation Keys	64
4.2	Main Screen	65
4.3	OC Tweaker Screen	66
4.4	Advanced Screen	70
4.4.1	CPU Configuration	71
4.4.2	Onboard Devices Configuration	72
4.4.3	Storage Configuration	74
4.4.4	ACPI Configuration	75
4.4.5	Trusted Computing	76
4.4.6	AMD CBS	77
4.4.7	AMD PBS	78

4.4.8	AMD Overclocking	79
4.5	Tools	80
4.6	Hardware Health Event Monitoring Screen	81
4.7	Security Screen	84
4.8	Boot Screen	85
4.9	Exit Screen	88



# Chapter 1 Introduction

Thank you for purchasing ASRock B550 Phantom Gaming 4/ac / B550 Phantom Gaming 4 motherboard, a reliable motherboard produced under ASRock's consistently stringent quality control. It delivers excellent performance with robust design conforming to ASRock's commitment to quality and endurance.

In this manual, Chapter 1 and 2 contains the introduction of the motherboard and step-by-step installation guides. Chapter 3 contains the operation guide of the software and utilities. Chapter 4 contains the configuration guide of the BIOS setup.



*Because the motherboard specifications and the BIOS software might be updated, the content of this manual will be subject to change without notice. In case any modifications of this manual occur, the updated version will be available on ASRock's website without further notice. If you require technical support related to this motherboard, please visit our website for specific information about the model you are using. You may find the latest VGA cards and CPU support list on ASRock's website as well. ASRock website <http://www.asrock.com>.*

## 1.1 Package Contents

- ASRock B550 Phantom Gaming 4/ac / B550 Phantom Gaming 4 Motherboard (ATX Form Factor)
- ASRock B550 Phantom Gaming 4/ac / B550 Phantom Gaming 4 Quick Installation Guide
- ASRock B550 Phantom Gaming 4/ac / B550 Phantom Gaming 4 Support CD
- 2 x Serial ATA (SATA) Data Cables (Optional)
- 2 x ASRock WiFi 2.4/5 GHz Antennas (Optional) (B550 Phantom Gaming 4/ac)
- 1 x Screw for M.2 Socket (Optional) (B550 Phantom Gaming 4/ac)
- 3 x Screws for M.2 Sockets (Optional) (B550 Phantom Gaming 4)
- 1 x I/O Panel Shield

## 1.2 Specifications

- Platform**
- ATX Form Factor
  - Solid Capacitor design
  - 2oz Copper PCB

- CPU**
- Supports AMD AM4 Socket Ryzen™ 3000, 3000 G-Series, 4000 G-Series, 5000 and 5000 G-Series Desktop Processors\*
- \* Please refer to CPU support list for details.
- Digi Power design
  - 8 Power Phase design

- Chipset**
- AMD B550

- Memory**
- Dual Channel DDR4 Memory Technology
  - 4 x DDR4 DIMM Slots
  - AMD Ryzen series CPUs (Vermeer) support DDR4 4533+(OC)/4466(OC)/4400(OC)/4333(OC)/4266(OC)/4200(OC)/4133(OC)/4000(OC)/3866(OC)/3800(OC)/3733(OC)/3600(OC)/3466(OC)/3200/2933/2667/2400/2133 ECC & non-ECC, un-buffered memory\*
  - AMD Ryzen series CPUs (Matisse) support DDR4 4533+(OC)/4466(OC)/4400(OC)/4333(OC)/4266(OC)/4200(OC)/4133(OC)/4000(OC)/3866(OC)/3800(OC)/3733(OC)/3600(OC)/3466(OC)/3200/2933/2667/2400/2133 ECC & non-ECC, un-buffered memory\*
  - AMD Ryzen series APUs (Cezanne) support DDR4 4733+(OC)/4666(OC)/4600(OC)/4533(OC)/4466(OC)/4400(OC)/4333(OC)/4266(OC)/4200(OC)/4133(OC)/4000(OC)/3866(OC)/3800(OC)/3733(OC)/3600(OC)/3466(OC)/3200/2933/2667/2400/2133 ECC & non-ECC, un-buffered memory\*
  - AMD Ryzen series APUs (Renoir) support DDR4 4733+(OC)/4666(OC)/4600(OC)/4533(OC)/4466(OC)/4400(OC)/4333(OC)/4266(OC)/4200(OC)/4133(OC)/4000(OC)/3866(OC)/3800(OC)/3733(OC)/3600(OC)/3466(OC)/3200/2933/2667/2400/2133 ECC & non-ECC, un-buffered memory\*
  - AMD Ryzen series APUs (Picasso) support DDR4 3333+(OC)/3200(OC)/2933/2667/2400/2133 non-ECC, un-buffered memory\*

\* For Ryzen Series APUs (Picasso, Cezanne and Renoir), ECC is only supported with PRO CPUs.

\* Please refer to Memory Support List on ASRock's website for more information. (<http://www.asrock.com/>)

\* Please refer to page 27 for AMD non-XMP memory frequency support.

- Max. capacity of system memory: 128GB
- Supports Extreme Memory Profile (XMP) memory modules
- 15 $\mu$  Gold Contact in DIMM Slots

### **Expansion Slot**

#### **AMD Ryzen series CPUs (Vermeer and Matisse)**

- 2 x PCI Express x16 Slots (PCIe1: Gen4x16 mode; PCIe3: Gen3 x4 mode)\*

#### **AMD Ryzen series APUs (Cezanne and Renoir)**

- 2 x PCI Express x16 Slots (PCIe1: Gen3x16 mode; PCIe3: Gen3 x4 mode)\*

#### **AMD Ryzen series APUs (Picasso)**

- 2 x PCI Express x16 Slots (PCIe1: Gen3x8 mode; PCIe3: Gen3 x4 mode)\*

\* Supports NVMe SSD as boot disks

- 2 x PCI Express 3.0 x1 Slots
- Supports AMD Quad CrossFireX™ and CrossFireX™
- 1 x M.2 Socket (Key E), supports type 2230 WiFi/BT module

### **Graphics**

- **Integrated AMD Radeon™ Vega Series Graphics in Ryzen Series APU\***

\* Actual support may vary by CPU

- DirectX 12, Pixel Shader 5.0
- Shared memory default 2GB. Max Shared memory supports up to 16GB.

\* The Max shared memory 16GB requires 32GB system memory installed.

- Supports HDMI 2.1 with max. resolution up to 4K x 2K (4096x2160) @ 60Hz
- Supports Auto Lip Sync, Deep Color (12bpc), xvYCC and HBR (High Bit Rate Audio) with HDMI 2.1 Port (Compliant HDMI monitor is required)

- Supports HDR (High Dynamic Range) with HDMI 2.1
- Supports HDCP 2.3 with HDMI 2.1 Port
- \* Picasso supports HDCP 2.2 with HDMI 2.0 Port
- Supports 4K Ultra HD (UHD) playback with HDMI 2.1 Port
- Supports Microsoft PlayReady®

### **Audio**

- 7.1 CH HD Audio with Content Protection (Realtek ALC1220/ALC1200 Audio Codec)
- Premium Blu-ray Audio support
- Supports Surge Protection
- PCB Isolate Shielding
- Individual PCB Layers for R/L Audio Channel
- Nahimic Audio

### **LAN**

- PCIE x1 Gigabit LAN 10/100/1000 Mb/s
- Realtek RTL8111H
- Supports Wake-On-LAN
- Supports Lightning/ESD Protection
- Supports Energy Efficient Ethernet 802.3az
- Supports PXE

### **Wireless**

#### **LAN**

#### **(For B550**

#### **Phantom**

#### **Gaming 4/**

#### **ac)**

- Intel® 802.11ac WiFi Module
- Supports IEEE 802.11a/b/g/n/ac
- Supports Dual-Band (2.4/5 GHz)
- Supports high speed wireless connections up to 433Mbps
- Supports Bluetooth 4.2 + High speed class II

### **Rear Panel**

#### **I/O**

- 2 x Antenna Ports (B550 Phantom Gaming 4/ac)
- Antenna Bracket (B550 Phantom Gaming 4)
- 1 x PS/2 Mouse/Keyboard Port
- 1 x HDMI Port
- 6 x USB 3.2 Gen1 Ports (Supports ESD Protection)
- 1 x RJ-45 LAN Port with LED (ACT/LINK LED and SPEED LED)
- HD Audio Jacks: Line in / Front Speaker / Microphone

## Storage

### B550 Phantom Gaming 4/ac:

- 4 x SATA3 6.0 Gb/s Connectors, support RAID (RAID 0, RAID 1 and RAID 10), NCQ, AHCI and Hot Plug
- 1 x Hyper M.2 Socket (M2\_1), supports M Key type 2260/2280/22110 M.2 PCI Express module up to Gen4x4 (64 Gb/s) (with Vermeer, Matisse) or Gen3x4 (32 Gb/s) (with Cezanne, Renoir and Picasso)\*

\* Supports NVMe SSD as boot disks

\* Supports ASRock U.2 Kit

### B550 Phantom Gaming 4:

- 6 x SATA3 6.0 Gb/s Connectors, support RAID (RAID 0, RAID 1 and RAID 10), NCQ, AHCI and Hot Plug\*
- \* M2\_3 and SATA3\_5\_6 share lanes. If either one of them is in use, the other one will be disabled.
- 1 x Hyper M.2 Socket (M2\_1), supports M Key type 2260/2280/22110 M.2 PCI Express module up to Gen4x4 (64 Gb/s) (with Vermeer, Matisse) or Gen3x4 (32 Gb/s) (with Cezanne, Renoir and Picasso)\*\*
- 1 x M.2 Socket (M2\_3), supports M Key type 2242/2260/2280 M.2 SATA3 6.0 Gb/s module and M.2 PCI Express module up to Gen3 x2 (16 Gb/s)\*\*

\*\* Supports NVMe SSD as boot disks

\*\* Supports ASRock U.2 Kit

## Connector

- 1 x COM Port Header
- 1 x SPI TPM Header
- 1 x Power LED and Speaker Header
- 2 x RGB LED Headers

\* Support in total up to 12V/3A, 36W LED Strip

- 2 x Addressable LED Headers

\* Support in total up to 5V/3A, 15W LED Strip

- 1 x CPU Fan Connector (4-pin)

\* The CPU Fan Connector supports the CPU fan of maximum 1A (12W) fan power.

- 1 x CPU/Water Pump Fan Connector (4-pin) (Smart Fan Speed Control)
- 4 x Chassis/Water Pump Fan Connectors (4-pin) (Smart Fan Speed Control)

\* The Chassis/Water Pump Fan supports the water cooler fan of maximum 2A (24W) fan power.

\* CPU\_FAN2/WP, CHA\_FAN1/WP, CHA\_FAN2/WP, CHA\_FAN3/WP and CHA\_FAN4/WP can auto detect if 3-pin or 4-pin fan is in use.

- 1 x 24 pin ATX Power Connector
- 1 x 8 pin 12V Power Connector
- 1 x 4 pin 12V Power Connector
- 1 x Front Panel Audio Connector
- 2 x USB 2.0 Headers (Support 4 USB 2.0 ports) (Supports ESD Protection)
- 1 x USB 3.2 Gen1 Header (Supports 2 USB 3.2 Gen1 ports) (Supports ESD Protection)

#### **BIOS Feature**

- AMI UEFI Legal BIOS with GUI support
- Supports “Plug and Play”
- ACPI 5.1 compliance wake up events
- Supports jumperfree
- SMBIOS 2.3 support
- CPU, CPU VDDCR\_SOC, DRAM, VPPM, 1.05V\_PROM\_S5, 2.5V\_PROM, +1.8VSB, VDDP Voltage Multi-adjustment

#### **Hardware Monitor**

- Temperature Sensing: CPU, CPU/Water Pump, Chassis/Water Pump Fans
- Fan Tachometer: CPU, CPU/Water Pump, Chassis/Water Pump Fans
- Quiet Fan (Auto adjust chassis fan speed by CPU temperature): CPU, CPU/Water Pump, Chassis/Water Pump Fans
- Fan Multi-Speed Control: CPU, CPU/Water Pump, Chassis/Water Pump Fans
- Voltage monitoring: +12V, +5V, +3.3V, CPU Vcore, CPU VDDCR\_SOC, DRAM, VPPM, 1.05V\_PROM\_S5, +1.8V, VDDP

#### **OS**

- Microsoft® Windows® 10 64-bit / 11 64-bit

#### **Certifications**

- FCC, CE
- ErP/EuP ready (ErP/EuP ready power supply is required)

\* For detailed product information, please visit our website: <http://www.asrock.com>



*Please realize that there is a certain risk involved with overclocking, including adjusting the setting in the BIOS, applying Untied Overclocking Technology, or using third-party overclocking tools. Overclocking may affect your system's stability, or even cause damage to the components and devices of your system. It should be done at your own risk and expense. We are not responsible for possible damage caused by overclocking.*

# 1.3 Motherboard Layout

## B550 Phantom Gaming 4/ac

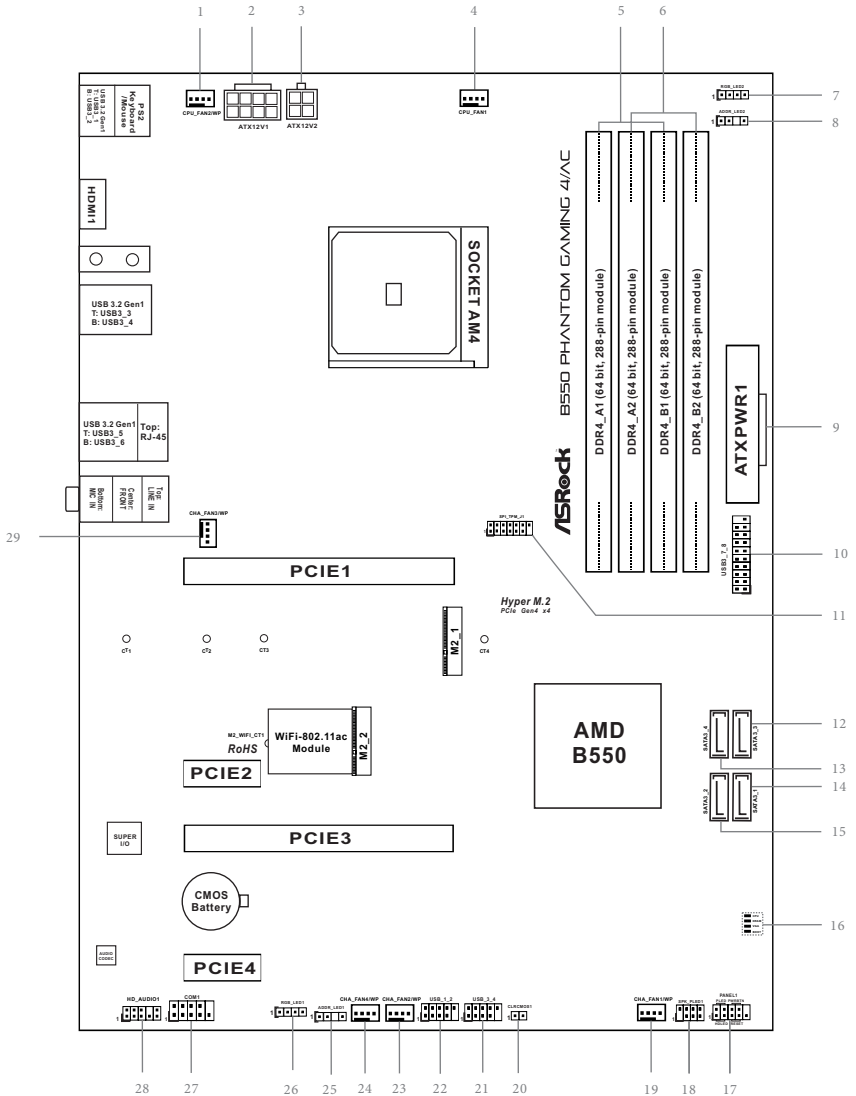

No.	Description
1	CPU Fan / Waterpump Fan Connector (CPU_FAN2/WP)
2	ATX 12V Power Connector (ATX12V1)
3	ATX 12V Power Connector (ATX12V2)
4	CPU Fan Connector (CPU_FAN1)
5	2 x 288-pin DDR4 DIMM Slots (DDR4_A1, DDR4_B1)
6	2 x 288-pin DDR4 DIMM Slots (DDR4_A2, DDR4_B2)
7	RGB LED Header (RGB_LED2)
8	Addressable LED Header (ADDR_LED2)
9	ATX Power Connector (ATXPWR1)
10	USB 3.2 Gen1 Header (USB3_7_8)
11	SPI TPM Header (SPI_TPM_J1)
12	SATA3 Connector (SATA3_3)
13	SATA3 Connector (SATA3_4)
14	SATA3 Connector (SATA3_1)
15	SATA3 Connector (SATA3_2)
16	Post Status Checker (PSC)
17	System Panel Header (PANEL1)
18	Power LED and Speaker Header (SPK_PLED1)
19	Chassis Fan / Waterpump Fan Connector (CHA_FAN1/WP)
20	Clear CMOS Jumper (CLRCMOS1)
21	USB 2.0 Header (USB_3_4)
22	USB 2.0 Header (USB_1_2)
23	Chassis Fan / Waterpump Fan Connector (CHA_FAN2/WP)
24	Chassis Fan / Waterpump Fan Connector (CHA_FAN4/WP)
25	Addressable LED Header (ADDR_LED1)
26	RGB LED Header (RGB_LED1)
27	COM Port Header (COM1)
28	Front Panel Audio Header (HD_AUDIO1)
29	Chassis Fan / Waterpump Fan Connector (CHA_FAN3/WP)



No.	Description
1	CPU Fan / Waterpump Fan Connector (CPU_FAN2/WP)
2	ATX 12V Power Connector (ATX12V1)
3	ATX 12V Power Connector (ATX12V2)
4	CPU Fan Connector (CPU_FAN1)
5	2 x 288-pin DDR4 DIMM Slots (DDR4_A1, DDR4_B1)
6	2 x 288-pin DDR4 DIMM Slots (DDR4_A2, DDR4_B2)
7	RGB LED Header (RGB_LED2)
8	Addressable LED Header (ADDR_LED2)
9	ATX Power Connector (ATXPWR1)
10	USB 3.2 Gen1 Header (USB3_7_8)
11	SPI TPM Header (SPI_TPM_J1)
12	SATA3 Connector (SATA3_5)
13	SATA3 Connector (SATA3_6)
14	SATA3 Connector (SATA3_3)
15	SATA3 Connector (SATA3_4)
16	SATA3 Connector (SATA3_1)
17	SATA3 Connector (SATA3_2)
18	Post Status Checker (PSC)
19	System Panel Header (PANEL1)
20	Power LED and Speaker Header (SPK_PLED1)
21	Chassis Fan / Waterpump Fan Connector (CHA_FAN1/WP)
22	Clear CMOS Jumper (CLRCMOS1)
23	USB 2.0 Header (USB_3_4)
24	USB 2.0 Header (USB_1_2)
25	Chassis Fan / Waterpump Fan Connector (CHA_FAN2/WP)
26	Chassis Fan / Waterpump Fan Connector (CHA_FAN4/WP)
27	Addressable LED Header (ADDR_LED1)
28	RGB LED Header (RGB_LED1)
29	COM Port Header (COM1)
30	Front Panel Audio Header (HD_AUDIO1)
31	Chassis Fan / Waterpump Fan Connector (CHA_FAN3/WP)

## 1.4 I/O Panel

### B550 Phantom Gaming 4/ac

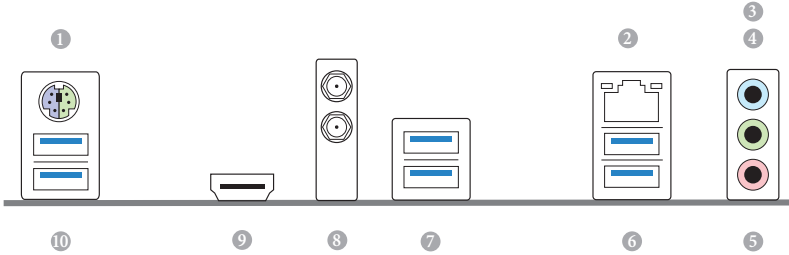

No.	Description	No.	Description
1	PS/2 Mouse/Keyboard Port	6	USB 3.2 Gen1 Ports (USB3_5_6)
2	LAN RJ-45 Port*	7	USB 3.2 Gen1 Ports (USB3_3_4)
3	Line In (Light Blue)**	8	Antenna Ports
4	Front Speaker (Lime)**	9	HDMI Port
5	Microphone (Pink)**	10	USB 3.2 Gen1 Ports (USB3_1_2)

### B550 Phantom Gaming 4

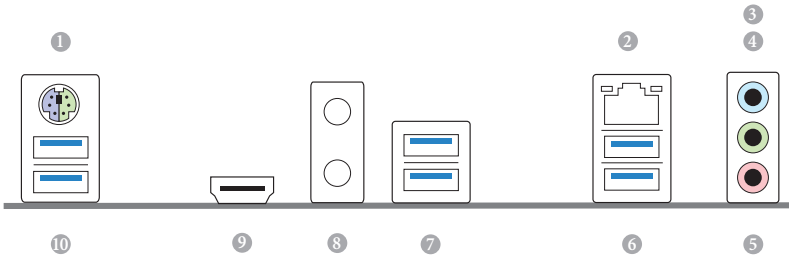

No.	Description	No.	Description
1	PS/2 Mouse/Keyboard Port	6	USB 3.2 Gen1 Ports (USB3_5_6)
2	LAN RJ-45 Port*	7	USB 3.2 Gen1 Ports (USB3_3_4)
3	Line In (Light Blue)**	8	Antenna Bracket
4	Front Speaker (Lime)**	9	HDMI Port
5	Microphone (Pink)**	10	USB 3.2 Gen1 Ports (USB3_1_2)

\* There are two LEDs on each LAN port. Please refer to the table below for the LAN port LED indications.

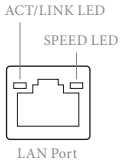

Activity / Link LED		Speed LED	
Status	Description	Status	Description
Off	No Link	Off	10Mbps connection
Blinking	Data Activity	Orange	100Mbps connection
On	Link	Green	1Gbps connection

\*\* Function of the Audio Ports in 7.1-channel Configuration:

Port	Function
Light Blue (Rear panel)	Rear Speaker Out
Lime (Rear panel)	Front Speaker Out
Pink (Rear panel)	Central /Subwoofer Speaker Out
Lime (Front panel)	Side Speaker Out

## 1.5 WiFi-802.11ac Module and ASRock WiFi 2.4/5 GHz Antennas (For B550 Phantom Gaming 4/ac)

### WiFi-802.11ac + BT Module

This motherboard comes with an exclusive WiFi 802.11 a/b/g/n/ac + BT v4.2 module that offers support for WiFi 802.11 a/b/g/n/ac connectivity standards and Bluetooth v4.2. WiFi + BT module is an easy-to-use wireless local area network (WLAN) adapter to support WiFi + BT. Bluetooth v4.2 standard features Smart Ready technology that adds a whole new class of functionality into the mobile devices. BT 4.2 also includes Low Energy Technology and ensures extraordinary low power consumption for PCs.

\* The transmission speed may vary according to the environment.

## WiFi Antennas Installation Guide



### Step 1

Prepare the WiFi 2.4/5 GHz Antennas that come with the package.

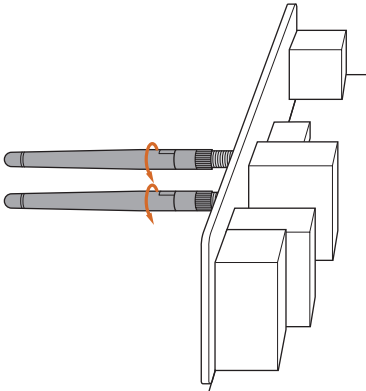

### Step 2

Connect the two WiFi 2.4/5 GHz Antennas to the antenna connectors. Turn the antenna clockwise until it is securely connected.

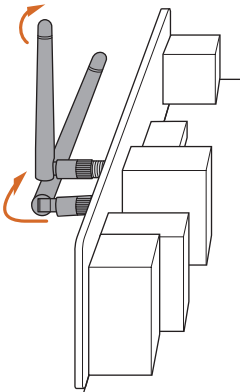

### Step 3

Set the WiFi 2.4/5 GHz Antenna as shown in the illustration.

\*You may need to adjust the direction of the antenna for a stronger signal.

# Chapter 2 Installation

This is an ATX form factor motherboard. Before you install the motherboard, study the configuration of your chassis to ensure that the motherboard fits into it.

## Pre-installation Precautions

Take note of the following precautions before you install motherboard components or change any motherboard settings.

- Make sure to unplug the power cord before installing or removing the motherboard. Failure to do so may cause physical injuries to you and damages to motherboard components.
- In order to avoid damage from static electricity to the motherboard's components, NEVER place your motherboard directly on a carpet. Also remember to use a grounded wrist strap or touch a safety grounded object before you handle the components.
- Hold components by the edges and do not touch the ICs.
- Whenever you uninstall any components, place them on a grounded anti-static pad or in the bag that comes with the components.
- When placing screws to secure the motherboard to the chassis, please do not over-tighten the screws! Doing so may damage the motherboard.

## 2.1 Installing the CPU



*Unplug all power cables before installing the CPU.*

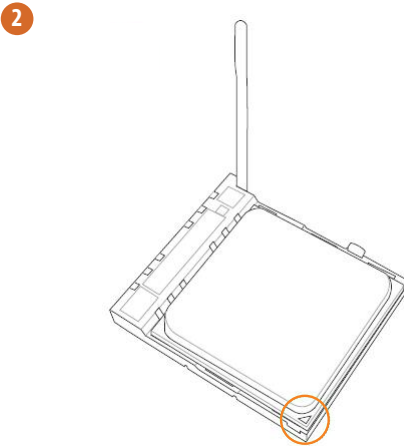
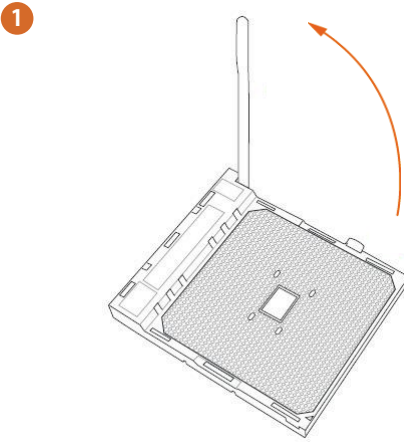

3



## 2.2 Installing the CPU Fan and Heatsink

After you install the CPU into this motherboard, it is necessary to install a larger heatsink and cooling fan to dissipate heat. You also need to spray thermal grease between the CPU and the heatsink to improve heat dissipation. Make sure that the CPU and the heatsink are securely fastened and in good contact with each other.



*Please turn off the power or remove the power cord before changing a CPU or heatsink.*

### Installing the CPU Box Cooler SR1

1

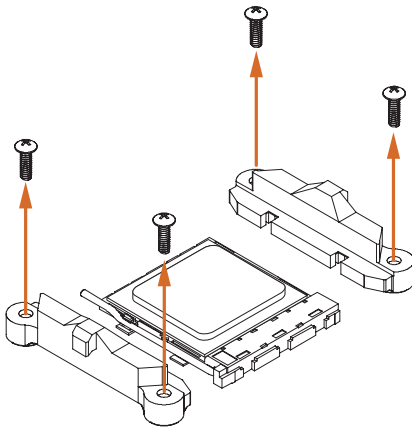

2

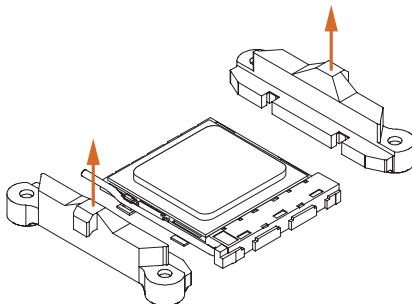

3

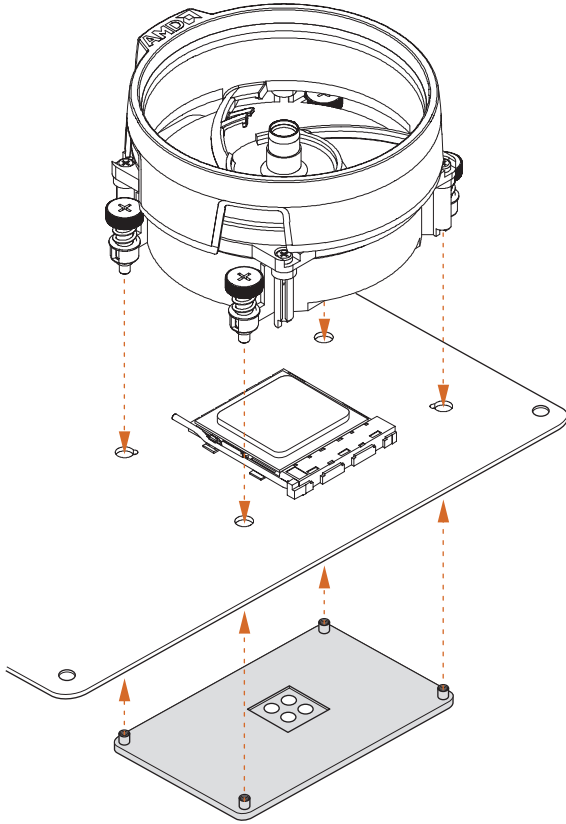

4

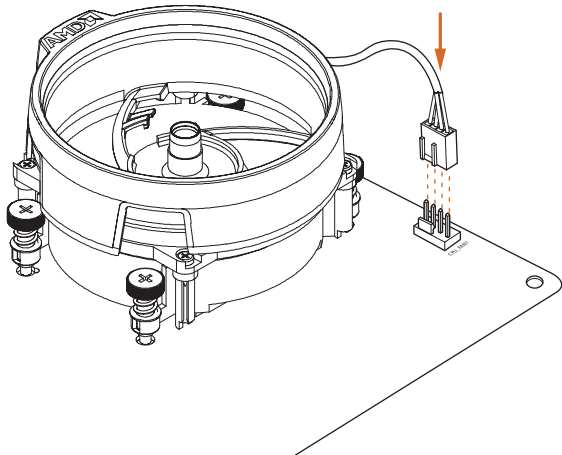

## Installing the AM4 Box Cooler SR2

1

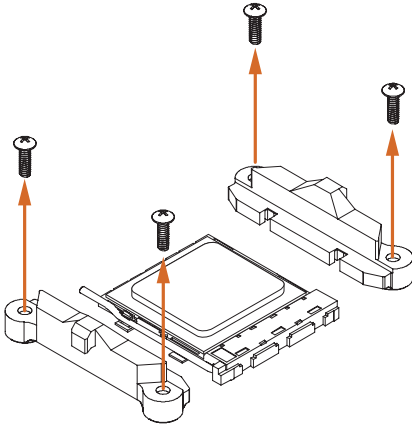

2

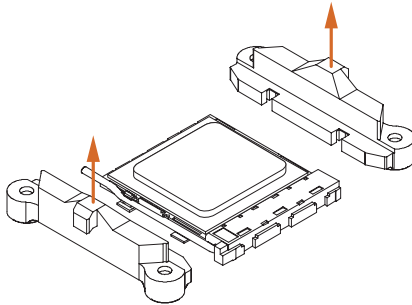

3

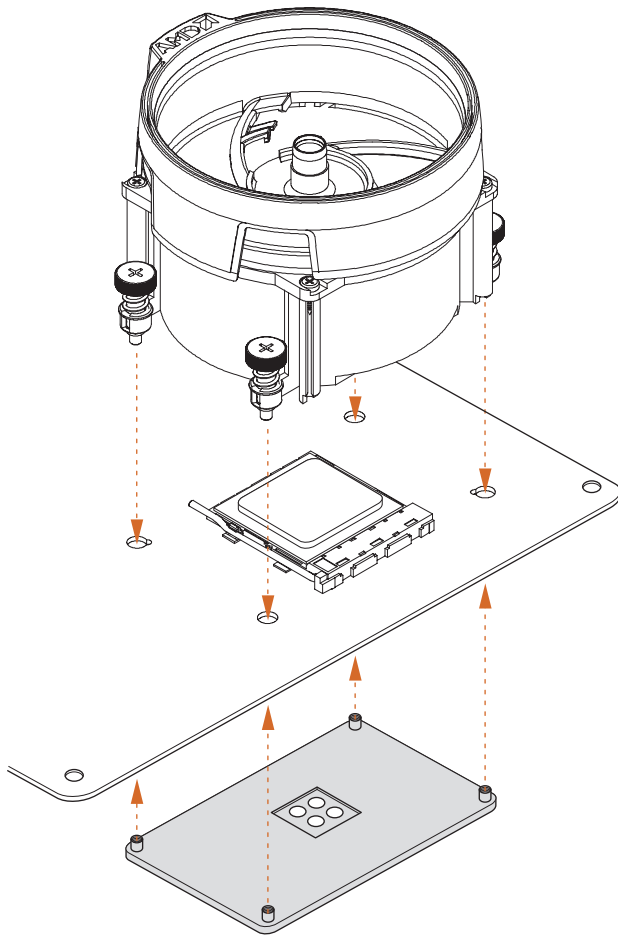

4

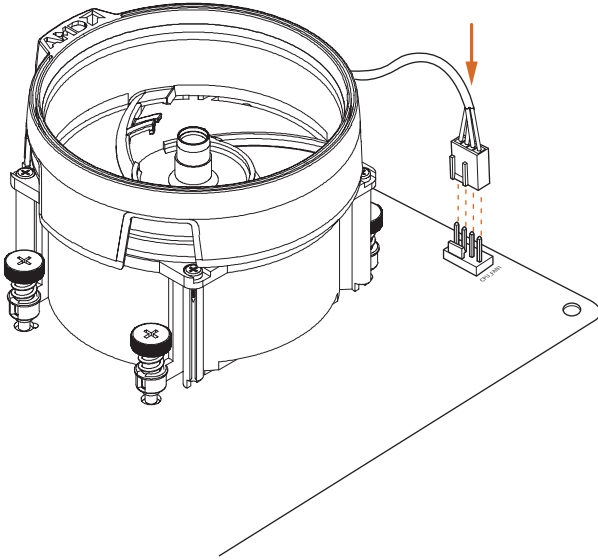

\*The diagrams shown here are for reference only. The header might be in a different position on your motherboard.

## Installing the AM4 Box Cooler SR3

1

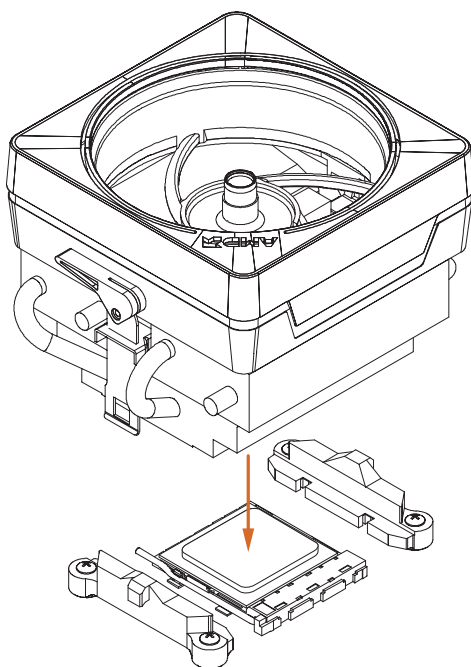

2

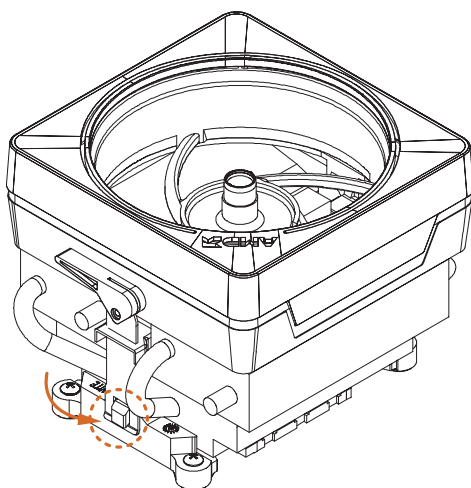

3

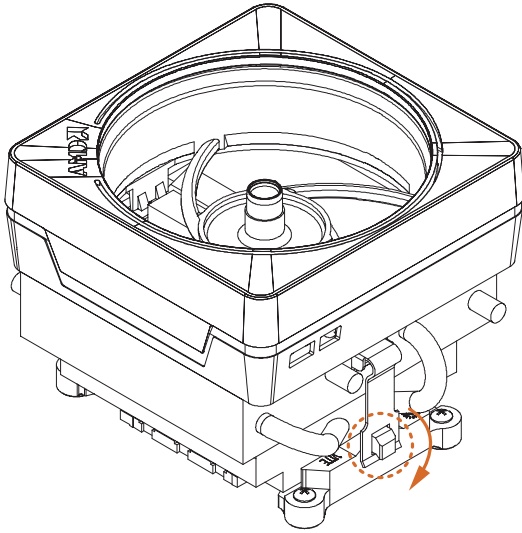

4

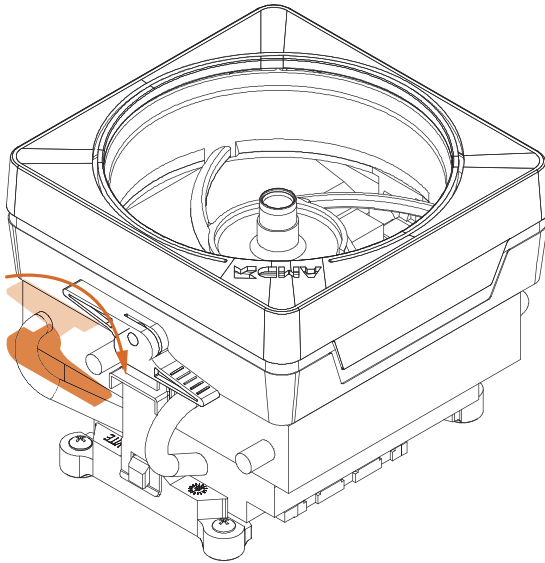

5

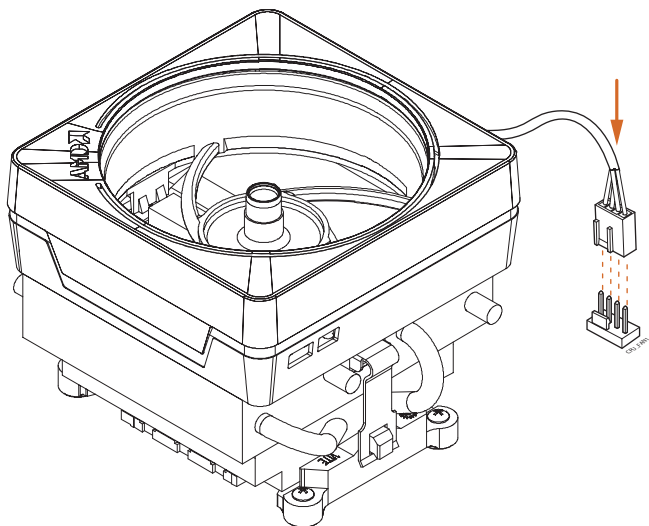

6

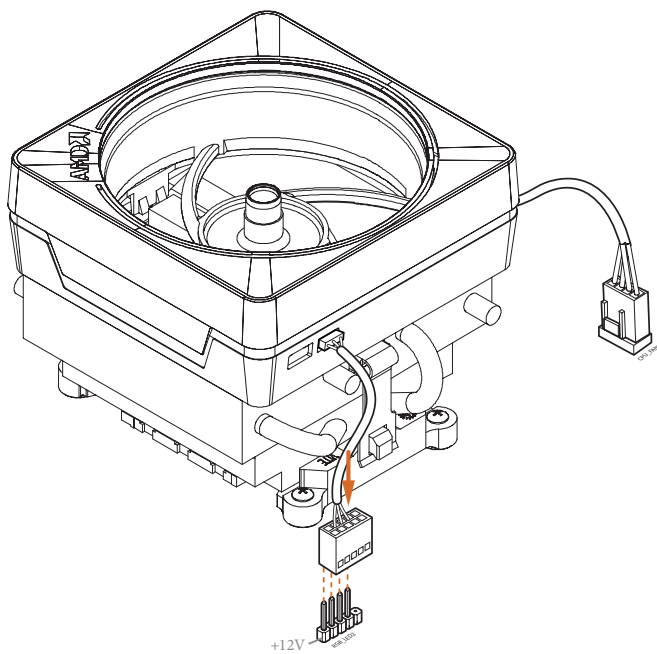

\*The diagrams shown here are for reference only. The header might be in a different position on your motherboard.

## 2.3 Installing Memory Modules (DIMM)

This motherboard provides four 288-pin DDR4 (Double Data Rate 4) DIMM slots, and supports Dual Channel Memory Technology.



1. For dual channel configuration, you always need to install identical (the same brand, speed, size and chip-type) DDR4 DIMM pairs.
2. It is unable to activate Dual Channel Memory Technology with only one or three memory module installed.
3. It is not allowed to install a DDR, DDR2 or DDR3 memory module into a DDR4 slot; otherwise, this motherboard and DIMM may be damaged.
4. We suggest that you install the memory modules on DDR4\_A2 and DDR4\_B2 first for better DRAM compatibility on 2 DIMMs configuration.

### AMD non-XMP Memory Frequency Support

Ryzen Series CPUs (Vermeer and Matisse):

UDIMM Memory Slot				Frequency
A1	A2	B1	B2	(Mhz)
-	SR	-	-	3200
-	DR	-	-	3200
-	SR	-	SR	3200
-	DR	-	DR	3200
SR	SR	SR	SR	2933
SR/DR	DR	SR/DR	DR	2667
SR/DR	SR/DR	SR/DR	SR/DR	2667

Ryzen Series APUs (Cezanne and Renoir):

UDIMM Memory Slot				Frequency
A1	A2	B1	B2	(Mhz)
-	SR	-	-	3200
-	DR	-	-	3200
-	SR	-	SR	3200
-	DR	-	DR	3200
SR	SR	SR	SR	2933
SR/DR	DR	SR/DR	DR	2667
SR/DR	SR/DR	SR/DR	SR/DR	2667

Ryzen Series APUs (Picasso):

UDIMM Memory Slot				Frequency
A1	A2	B1	B2	(Mhz)
-	SR	-	-	2933
-	DR	-	-	2667
-	SR	-	SR	2667
-	DR	-	DR	2400
SR	SR	SR	SR	2133
SR/DR	DR	SR/DR	DR	1866
SR/DR	SR/DR	SR/DR	SR/DR	1866

SR: Single rank DIMM, 1Rx4 or 1Rx8 on DIMM module label

DR: Dual rank DIMM, 2Rx4 or 2Rx8 on DIMM module label



*The DIMM only fits in one correct orientation. It will cause permanent damage to the motherboard and the DIMM if you force the DIMM into the slot at incorrect orientation.*

1

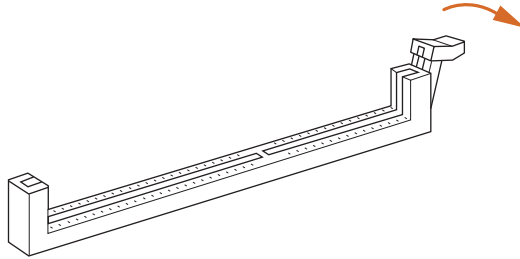

2

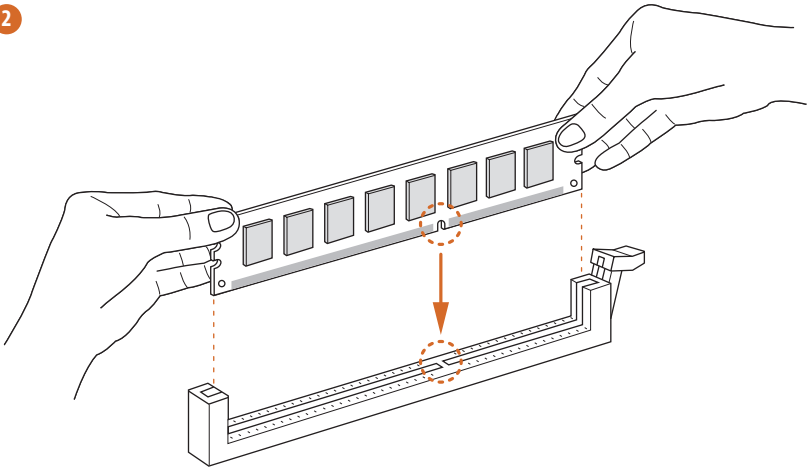

3

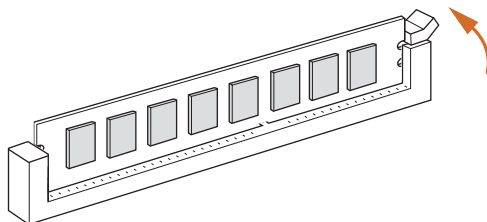

## 2.4 Expansion Slots (PCI Express Slots)

There are 4 PCI Express slots on the motherboard.



*Before installing an expansion card, please make sure that the power supply is switched off or the power cord is unplugged. Please read the documentation of the expansion card and make necessary hardware settings for the card before you start the installation.*

### PCIe slots:

PCIe1 (PCIe 4.0 x16 slot) is used for PCI Express x16 lane width graphics cards.

PCIe2 (PCIe 3.0 x1 slot) is used for PCI Express x1 lane width cards.

PCIe3 (PCIe 3.0 x16 slot) is used for PCI Express x4 lane width graphics cards.

PCIe4 (PCIe 3.0 x1 slot) is used for PCI Express x1 lane width cards.

	PCIe1	PCIe3
<b>Ryzen Series CPUs (Vermeer and Matisse)</b>	Gen4x16	Gen3x4
<b>Ryzen Series APUs (Cezanne and Renoir)</b>	Gen3x16	Gen3x4
<b>Ryzen Series APUs (Picasso)</b>	Gen3x8	Gen3x4



*For a better thermal environment, please connect a chassis fan to the motherboard's chassis fan connector (CHA\_FAN1/WP, CHA\_FAN2/WP, CHA\_FAN3/WP or CHA\_FAN4/WP) when using multiple graphics cards.*

## 2.5 Jumpers Setup

The illustration shows how jumpers are setup. When the jumper cap is placed on the pins, the jumper is “Short”. If no jumper cap is placed on the pins, the jumper is “Open”.

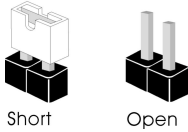

---

Clear CMOS Jumper  
(CLRCMOS1)  
(see p.8, No. 20)  
(see p.10, No. 22)

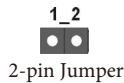

---

CLRCMOS2 allows you to clear the data in CMOS. To clear and reset the system parameters to default setup, please turn off the computer and unplug the power cord from the power supply. After waiting for 15 seconds, use a jumper cap to short the pins on CLRCMOS2 for 5 seconds. However, please do not clear the CMOS right after you update the BIOS. If you need to clear the CMOS when you just finish updating the BIOS, you must boot up the system first, and then shut it down before you do the clear-CMOS action. Please be noted that the password, date, time, and user default profile will be cleared only if the CMOS battery is removed. Please remember to remove the jumper cap after clearing the CMOS.

## 2.6 Onboard Headers and Connectors



Onboard headers and connectors are NOT jumpers. Do NOT place jumper caps over these headers and connectors. Placing jumper caps over the headers and connectors will cause permanent damage to the motherboard.

### System Panel Header

(9-pin PANEL1)

(see p.8, No. 17)

(see p.8, No. 19)

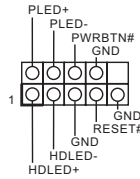

Connect the power switch, reset switch and system status indicator on the chassis to this header according to the pin assignments below. Note the positive and negative pins before connecting the cables.



#### **PWRBTN (Power Switch):**

Connect to the power switch on the chassis front panel. You may configure the way to turn off your system using the power switch.

#### **RESET (Reset Switch):**

Connect to the reset switch on the chassis front panel. Press the reset switch to restart the computer if the computer freezes and fails to perform a normal restart.

#### **PLED (System Power LED):**

Connect to the power status indicator on the chassis front panel. The LED is on when the system is operating. The LED keeps blinking when the system is in S3 sleep state. The LED is off when the system is in S4 sleep state or powered off (S5).

#### **HDLED (Hard Drive Activity LED):**

Connect to the hard drive activity LED on the chassis front panel. The LED is on when the hard drive is reading or writing data.

The front panel design may differ by chassis. A front panel module mainly consists of power switch, reset switch, power LED, hard drive activity LED, speaker and etc. When connecting your chassis front panel module to this header, make sure the wire assignments and the pin assignments are matched correctly.

**Power LED and Speaker Header**

(7-pin SPK\_PLED1)  
(see p.8, No. 18)  
(see p.10, No. 20)

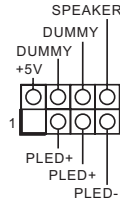

Please connect the chassis power LED and the chassis speaker to this header.

**B550 Phantom Gaming 4/ac:**

Serial ATA3 Connectors  
(SATA3\_1:  
see p.8, No. 14)  
(SATA3\_2:  
see p.8, No. 15)  
(SATA3\_3:  
see p.8, No. 12)  
(SATA3\_4:  
see p.8, No. 13)

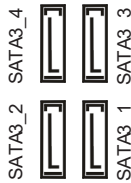

These four SATA3 connectors support SATA data cables for internal storage devices with up to 6.0 Gb/s data transfer rate.

**B550 Phantom Gaming 4:**

Serial ATA3 Connectors  
(SATA3\_1:  
see p.10, No. 16)  
(SATA3\_2:  
see p.10, No. 17)  
(SATA3\_3:  
see p.10, No. 14)  
(SATA3\_4:  
see p.10, No. 15)  
(SATA3\_5:  
see p.10, No. 12)  
(SATA3\_6:  
see p.10, No. 13)

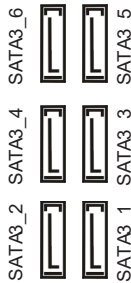

These six SATA3 connectors support SATA data cables for internal storage devices with up to 6.0 Gb/s data transfer rate.  
\* M2\_3 and SATA3\_5\_6 share lanes. If either one of them is in use, the other one will be disabled.

**USB 2.0 Headers**

(9-pin USB\_1\_2)  
(see p.8, No. 22)  
(see p.10, No. 24)  
(9-pin USB\_3\_4)  
(see p.8, No. 21)  
(see p.10, No. 23)

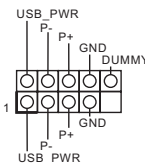

There are two headers on this motherboard. Each USB 2.0 header can support two ports.

USB 3.2 Gen1 Header  
(19-pin USB3\_7\_8)  
(see p.8, 10, No. 10)

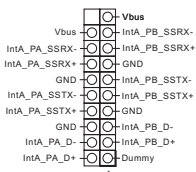

There is one header on this motherboard. Each USB 3.2 Gen1 header can support two ports.

Front Panel Audio Header  
(9-pin HD\_AUDIO1)  
(see p.8, No. 28)  
(see p.10, No. 30)

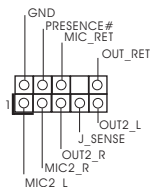

This header is for connecting audio devices to the front audio panel.



1. High Definition Audio supports Jack Sensing, but the panel wire on the chassis must support HDA to function correctly. Please follow the instructions in our manual and chassis manual to install your system.
2. If you use an AC'97 audio panel, please install it to the front panel audio header by the steps below:
  - A. Connect Mic\_IN (MIC) to MIC2\_L.
  - B. Connect Audio\_R (RIN) to OUT2\_R and Audio\_L (LIN) to OUT2\_L.
  - C. Connect Ground (GND) to Ground (GND).
  - D. MIC\_RET and OUT\_RET are for the HD audio panel only. You don't need to connect them for the AC'97 audio panel.
  - E. To activate the front mic, go to the "FrontMic" Tab in the Realtek Control panel and adjust "Recording Volume".

Chassis Fan / Waterpump  
Fan Connectors  
(4-pin CHA\_FAN1/WP)  
(see p.8, No. 19)  
(see p.10, No. 21)  
(4-pin CHA\_FAN2/WP)  
(see p.8, No. 23)  
(see p.10, No. 25)

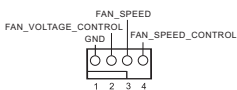

Please connect fan cables to the fan connectors and match the black wire to the ground pin.

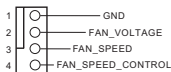

(4-pin CHA\_FAN3/WP)  
(see p.8, No. 29)  
(see p.10, No. 31)  
(4-pin CHA\_FAN4/WP)  
(see p.8, No. 24)  
(see p.10, No. 26)

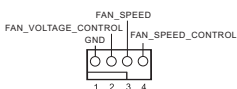

CPU Fan Connector  
(4-pin CPU\_FAN1)  
(see p.8, 10, No. 4)

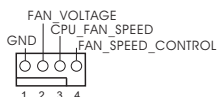

This motherboard provides a 4-Pin CPU fan (Quiet Fan) connector. If you plan to connect a 3-Pin CPU fan, please connect it to Pin 1-3.

CPU Fan / Waterpump Fan Connector  
(4-pin CPU\_FAN2/WP)  
(see p.8, 10, No. 1)

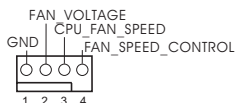

This motherboard provides a 4-Pin CPU fan (Quiet Fan) connector. If you plan to connect a 3-Pin CPU fan, please connect it to Pin 1-3.

ATX Power Connector  
(24-pin ATXPWR1)  
(see p.8, 10, No. 9)

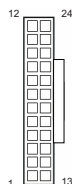

This motherboard provides a 24-pin ATX power connector. To use a 20-pin ATX power supply, please plug it along Pin 1 and Pin 13.

ATX 12V Power Connector  
(8-pin ATX12V1)  
(see p.8, 10, No. 2)

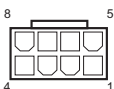

This motherboard provides a 8-pin ATX 12V power connector. To use a 4-pin ATX power supply, please plug it along Pin 1 and Pin 5.

ATX 12V Power Connector  
(4-pin ATX12V2)  
(see p.8, 10, No. 3)



Please connect an ATX 12V power supply to this connector.

\*The power supply plug fits into this connector in only one orientation.

---

Serial Port Header  
(9-pin COM1)  
(see p.8, No. 27)  
(see p.10, No. 29)

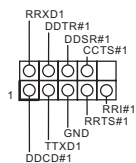

This COM1 header supports a serial port module.

---

SPI TPM Header  
(13-pin SPI\_TPM\_J1)  
(see p.8, 10, No. 11)

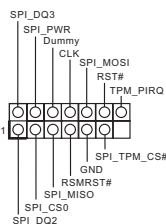

This connector supports SPI Trusted Platform Module (TPM) system, which can securely store keys, digital certificates, passwords, and data. A TPM system also helps enhance network security, protects digital identities, and ensures platform integrity.

---

RGB LED Headers  
(4-pin RGB\_LED1)  
(see p.8, No. 26)  
(see p.10, No. 28)  
(4-pin RGB\_LED2)  
(see p.8, 10, No. 7)



RGB headers are used to connect RGB LED extension cables which allow users to choose from various LED lighting effects.  
**Caution: Never install the RGB LED cable in the wrong orientation; otherwise, the cable may be damaged.**

\*Please refer to page 60 for further instructions on this header.

---

Addressable LED Headers  
(3-pin ADDR\_LED1)  
(see p.8, No. 25)  
(see p.10, No. 27)  
(3-pin ADDR\_LED2)  
(see p.8, 10, No. 8)

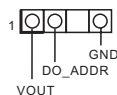

These headers are used to connect Addressable LED extension cables which allow users to choose from various LED lighting effects.

**Caution: Never install the Addressable LED cable in the wrong orientation; otherwise, the cable may be damaged.**

\*Please refer to page 61 for further instructions on this header.

## 2.7 Post Status Checker

Post Status Checker (PSC) diagnoses the computer when users power on the machine. It emits a red light to indicate whether the CPU, memory, VGA or storage is dysfunctional. The lights go off if the four mentioned above are functioning normally.

## 2.8 CrossFireX™ and Quad CrossFireX™ Operation Guide

This motherboard supports CrossFireX™ and Quad CrossFireX™ that allows you to install up to two identical PCI Express x16 graphics cards.



1. You should only use identical CrossFireX™-ready graphics cards that are AMD certified.
2. Make sure that your graphics card driver supports AMD CrossFireX™ technology. Download the drivers from the AMD's website: [www.amd.com](http://www.amd.com)
3. Make sure that your power supply unit (PSU) can provide at least the minimum power your system requires. It is recommended to use a AMD certified PSU. Please refer to the AMD's website for details.
4. If you pair a 12-pipe CrossFireX™ Edition card with a 16-pipe card, both cards will operate as 12-pipe cards while in CrossFireX™ mode.
5. Different CrossFireX™ cards may require different methods to enable CrossFireX™. Please refer to AMD graphics card manuals for detailed installation guide.

### 2.8.1 Installing Two CrossFireX™-Ready Graphics Cards

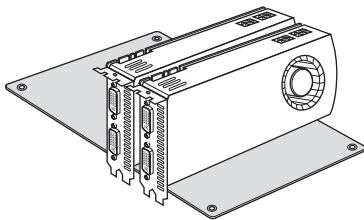

#### Step 1

Insert one graphics card into PCIE1 slot and the other graphics card to PCIE3 slot. Make sure that the cards are properly seated on the slots.



CrossFire Bridge

#### Step 2

Connect two graphics cards by installing a CrossFire Bridge on the CrossFire Bridge Interconnects on the top of the graphics cards. (The CrossFire Bridge is provided with the graphics card you purchase, not bundled with this motherboard. Please refer to your graphics card vendor for details.)

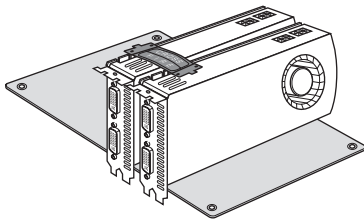

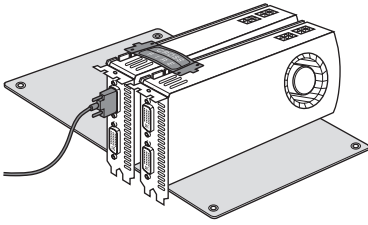

**Step 3**

Connect a VGA/DVI/DP/HDMI cable from the monitor to the corresponding port on the graphics card installed to the PCIe1 slot.

## 2.8.2 Driver Installation and Setup

### Step 1

Power on your computer and boot into OS.

### Step 2

Remove the AMD drivers if you have any VGA drivers installed in your system.



*The Catalyst Uninstaller is an optional download. We recommend using this utility to uninstall any previously installed Catalyst drivers prior to installation. Please check AMD's website for AMD driver updates.*

### Step 3

Install the required drivers and CATALYST Control Center then restart your computer. Please check AMD's website for details.



AMD Catalyst Control Center

### Step 4

Double-click the **AMD Catalyst Control Center** icon in the Windows' system tray.

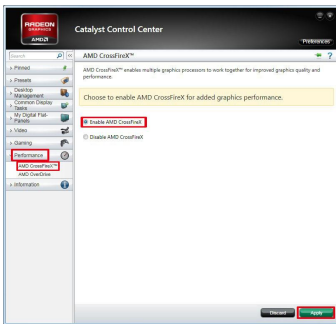

### Step 5

In the left pane, click **Performance** and then **AMD CrossFireX™**. Then select **Enable AMD CrossFireX** and click **Apply**. Select the GPU number according to your graphics card and click **Apply**.

## 2.9 M.2\_SSD (NGFF) Module Installation Guide (M2\_1)

The M.2, also known as the Next Generation Form Factor (NGFF), is a small size and versatile card edge connector that aims to replace mPCIe and mSATA. The Hyper M.2 Socket (M2\_1) supports M Key type 2260/2280/22110 M.2 PCI Express module up to Gen4x4 (64 Gb/s) (with Vermeer, Matisse) or Gen3x4 (32 Gb/s) (with Cezanne, Renoir and Picasso).

### Installing the M.2\_SSD (NGFF) Module

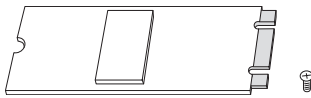

#### Step 1

Prepare a M.2\_SSD (NGFF) module and the screw.

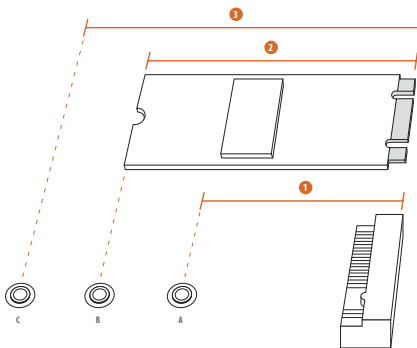

#### Step 2

Depending on the PCB type and length of your M.2\_SSD (NGFF) module, find the corresponding nut location to be used.

No.	1	2	3
Nut Location	A	B	C
PCB Length	6cm	8cm	11cm
Module Type	Type 2260	Type2280	Type 22110

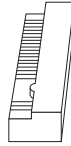
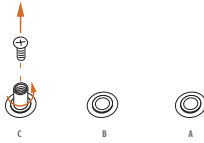

### Step 3

Move the standoff based on the module type and length. The standoff is placed at the nut location C by default. Skip Step 3 and 4 and go straight to Step 5 if you are going to use the default nut. Otherwise, release the standoff by hand.



### Step 4

Peel off the yellow protective film on the nut to be used. Hand tighten the standoff into the desired nut location on the motherboard.

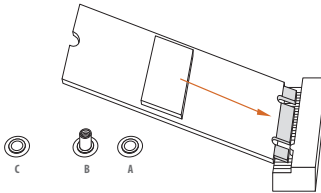
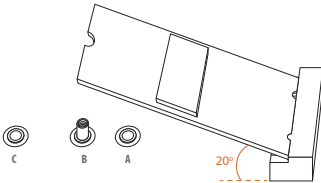

### Step 5

Gently insert the M.2 (NGFF) SSD module into the M.2 slot. Please be aware that the M.2 (NGFF) SSD module only fits in one orientation.

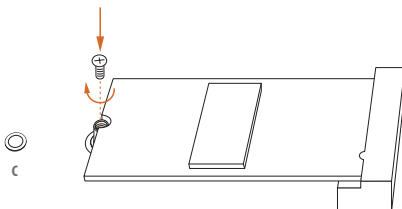

### Step 6

Tighten the screw with a screwdriver to secure the module into place. Please do not overtighten the screw as this might damage the module.

## M.2\_SSD (NGFF) Module Support List

Vendor	Interface	P/N
ADATA	PCIe3 x4	ASX7000NP-128GT-C
ADATA	PCIe3 x4	ASX8000NP-256GM-C
ADATA	PCIe3 x4	ASX7000NP-256GT-C
ADATA	PCIe3 x4	ASX8000NP-512GM-C
ADATA	PCIe3 x4	ASX7000NP-512GT-C
Apacer	PCIe3 x4	AP240GZ280
Corsair	PCIe3 x4	CSSD-F240GBMP500
Intel	PCIe3 x4	SSDPEKKF256G7
Intel	PCIe3 x4	SSDPEKKF512G7
Kingston	PCIe3 x4	SKC1000/480G
Kingston	PCIe2 x4	SH2280S3/480G
OCZ	PCIe3 x4	RVD400 -M2280-512G (NVME)
PATRIOT	PCIe3 x4	PH240GPM280SSDR NVME
Plextor	PCIe3 x4	PX-128M8PeG
Plextor	PCIe3 x4	PX-1TM8PeG
Plextor	PCIe3 x4	PX-256M8PeG
Plextor	PCIe3 x4	PX-512M8PeG
Plextor	PCIe	PX-G256M6e
Plextor	PCIe	PX-G512M6e
Samsung	PCIe3 x4	SM961 MZVPW128HEGM (NVM)
Samsung	PCIe3 x4	PM961 MZVLW128HEGR (NVME)
Samsung	PCIe3 x4	960 EVO (MZ-V6E250) (NVME)
Samsung	PCIe3 x4	960 EVO (MZ-V6E250BW) (NVME)
Samsung	PCIe3 x4	SM951 (NVME)
Samsung	PCIe3 x4	SM951 (MZHPV256HDGL)
Samsung	PCIe3 x4	SM951 (MZHPV512HDGL)
Samsung	PCIe3 x4	SM951 (NVME)
Samsung	PCIe x4	XP941-512G (MZHPU512HCGL)
SanDisk	PCIe	SD6PP4M-128G
SanDisk	PCIe	SD6PP4M-256G
TEAM	PCIe3 x4	TM8FP2240G0C101
TEAM	PCIe3 x4	TM8FP2480G0C110
WD	PCIe3 x4	WDS256G1X0C-00ENX0 (NVME)
WD	PCIe3 x4	WDS512G1X0C-00ENX0 (NVME)

For the latest updates of M.2\_SSD (NFGG) module support list, please visit our website for details: <http://www.asrock.com>

## 2.10 M.2 WiFi/BT Module Installation Guide (M2\_2) (For B550 Phantom Gaming 4)

The M.2, also known as the Next Generation Form Factor (NGFF), is a small size and versatile card edge connector that aims to replace mPCIe and mSATA. The M.2 Socket (Key E) supports type 2230 WiFi/BT module.

\* The M.2 socket does not support SATA M.2 SSDs.

### Installing the WiFi/BT module

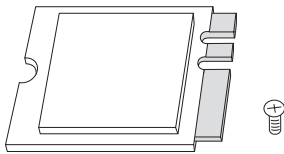

#### Step 1

Prepare a type 2230 WiFi/BT module and the screw.

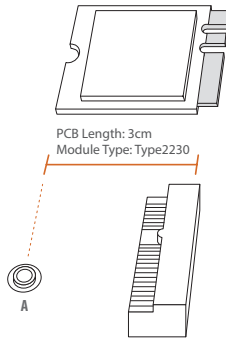

#### Step 2

Find the nut location to be used.

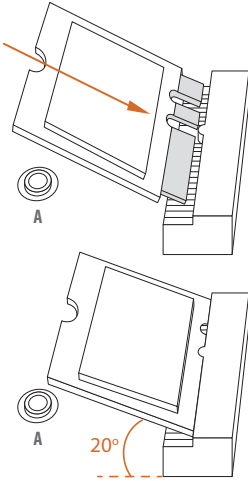

### Step 3

Gently insert the WiFi/BT module into the M.2 slot. Please be aware that the module only fits in one orientation.

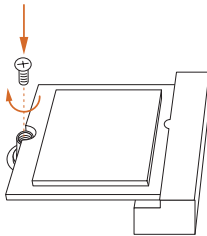

### Step 4

Tighten the screw with a screwdriver to secure the module into place. Please do not overtighten the screw as this might damage the module.

## 2.11 M.2\_SSD (NGFF) Module Installation Guide (M2\_3) (For B550 Phantom Gaming 4)

The M.2, also known as the Next Generation Form Factor (NGFF), is a small size and versatile card edge connector that aims to replace mPCIe and mSATA. The M.2 Socket (M2\_1) supports type 2242/2260/2280 M.2 SATA3 6.0 Gb/s module and M.2 PCI Express module up to Gen3 x2 (16 Gb/s).

\* M2\_3 and SATA3\_5\_6 share lanes. If either one of them is in use, the other one will be disabled.

### Installing the M.2\_SSD (NGFF) Module

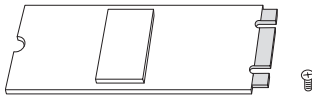

#### Step 1

Prepare a M.2\_SSD (NGFF) module and the screw.

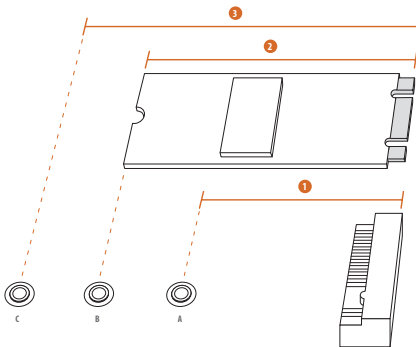

#### Step 2

Depending on the PCB type and length of your M.2\_SSD (NGFF) module, find the corresponding nut location to be used.

No.	1	2	3
Nut Location	A	B	C
PCB Length	4.2cm	6cm	8cm
Module Type	Type 2242	Type2260	Type 2280

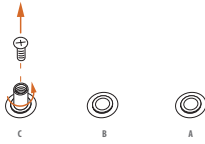

### Step 3

Move the standoff based on the module type and length. The standoff is placed at the nut location C by default. Skip Step 3 and 4 and go straight to Step 5 if you are going to use the default nut. Otherwise, release the standoff by hand.

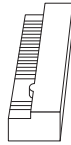

### Step 4

Peel off the yellow protective film on the nut to be used. Hand tighten the standoff into the desired nut location on the motherboard.

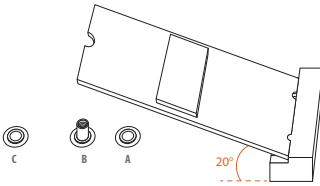

### Step 5

Gently insert the M.2 (NGFF) SSD module into the M.2 slot. Please be aware that the M.2 (NGFF) SSD module only fits in one orientation.

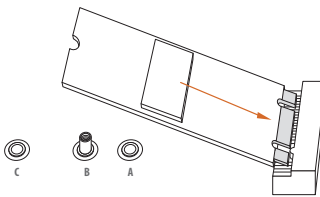

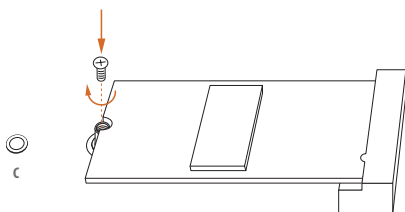

### Step 6

Tighten the screw with a screwdriver to secure the module into place. Please do not overtighten the screw as this might damage the module.

## M.2\_SSD (NGFF) Module Support List

Vendor	Interface	P/N
Intel	PCIe	INTEL 6000P-SSDPEKKF256G7 (nvme)
Intel	PCIe	INTEL 6000P-SSDPEKKF512G7 (nvme)
Intel	PCIe	INTEL 600P-SSDPEKKW256G7-256GB (nvme)
Kingston	PCIe	Kingston SHPM2280P2 / 240G (Gen2 x4)
SanDisk	PCIe	SanDisk-SD6PP4M-128G(Gen2 x2)
Samsung	PCIe	Samsung XP941-MZHPU512HCGL(Gen2x4)

For the latest updates of M.2\_SSD (NFGG) module support list, please visit our website for details: <http://www.asrock.com>

## Chapter 3 Software and Utilities Operation

### 3.1 Installing Drivers

The Support CD that comes with the motherboard contains necessary drivers and useful utilities that enhance the motherboard's features.

#### Running The Support CD

To begin using the support CD, insert the CD into your CD-ROM drive. The CD automatically displays the Main Menu if "AUTORUN" is enabled in your computer. If the Main Menu does not appear automatically, locate and double click on the file "ASRSETUP.EXE" in the Support CD to display the menu.

#### Drivers Menu

The drivers compatible to your system will be auto-detected and listed on the support CD driver page. Please click **Install All** or follow the order from top to bottom to install those required drivers. Therefore, the drivers you install can work properly.

#### Utilities Menu

The Utilities Menu shows the application software that the motherboard supports. Click on a specific item then follow the installation wizard to install it.

## 3.2 ASRock Motherboard Utility (Phantom Gaming Tuning)

ASRock Motherboard Utility (Phantom Gaming Tuning) is ASRock's multi purpose software suite with a new interface, more new features and improved utilities.

### 3.2.1 Installing ASRock Motherboard Utility (Phantom Gaming Tuning)

ASRock Motherboard Utility (Phantom Gaming Tuning) can be downloaded from ASRock Live Update & APP Shop. After the installation, you will find the icon "ASRock Motherboard Utility (Phantom Gaming Tuning)" on your desktop. Double-click the "ASRock Motherboard Utility (Phantom Gaming Tuning)" icon, ASRock Motherboard Utility (Phantom Gaming Tuning) main menu will pop up.

### 3.2.2 Using ASRock Motherboard Utility (Phantom Gaming Tuning)

There are five sections in ASRock Motherboard Utility (Phantom Gaming Tuning) main menu: Operation Mode, OC Tweaker, System Info, FAN-Tastic Tuning and Settings.

#### Operation Mode

Choose an operation mode for your computer.

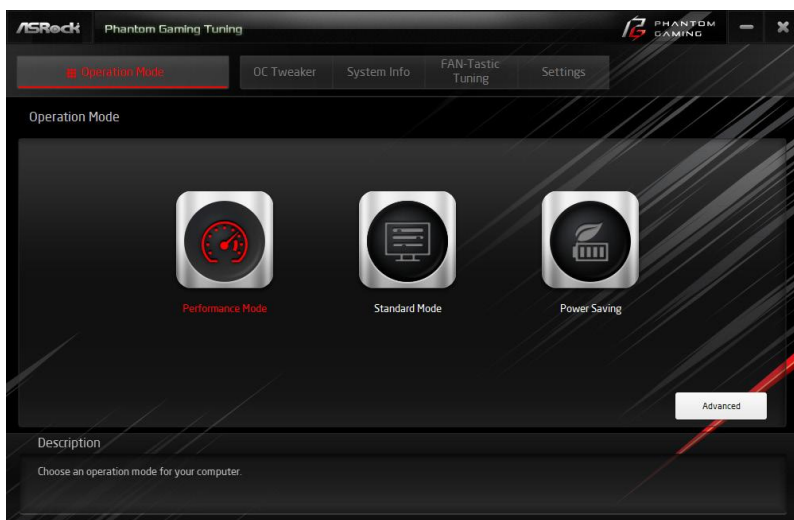

## OC Tweaker

Configurations for overclocking the system.



## System Info

View information about the system.

\*The System Browser tab may not appear for certain models.

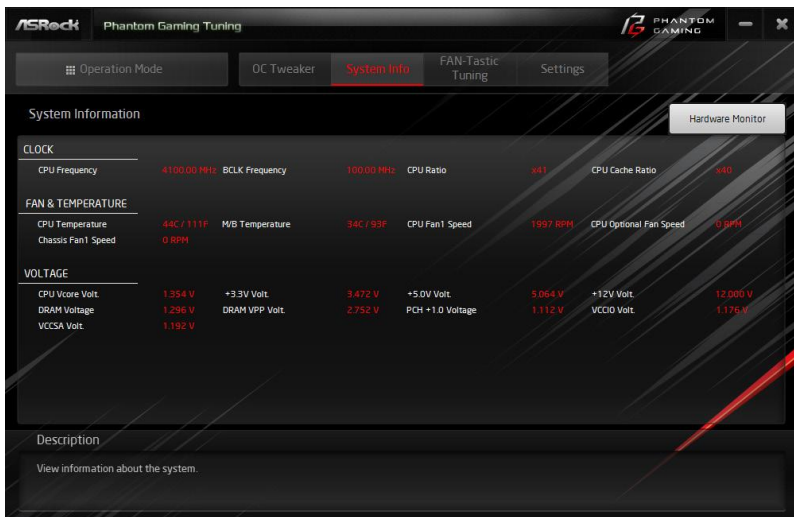

## FAN-Tastic Tuning

Configure up to five different fan speeds using the graph. The fans will automatically shift to the next speed level when the assigned temperature is met.

The screenshot shows the 'FAN-Tastic Tuning' window in ASRock Phantom Gaming Tuning. The 'FAN-Tastic Tuning' tab is active, showing a graph of Fan Speed (RPM) vs. Temperature (°C) and a table of Fan Power and Fan Speed settings. The 'Settings' tab is selected, showing the 'Auto run at Windows Startup' option.

Fan Power	Fan Speed
100%	N/A RPM
90%	N/A RPM
80%	N/A RPM
70%	N/A RPM
60%	N/A RPM
50%	N/A RPM
40%	N/A RPM
30%	N/A RPM
20%	N/A RPM
10%	N/A RPM

Auto apply when program starts

**Description**  
Configure different fan speeds for respective temperatures using the graph. The fans will automatically shift to the next speed level when the assigned temperature is met.

## Settings

Configure ASRock Motherboard Utility (Phantom Gaming Tuning). Click to select "Auto run at Windows Startup" if you want ASRock Motherboard Utility (Phantom Gaming Tuning) to be launched when you start up the Windows operating system.

The screenshot shows the 'Settings' window in ASRock Phantom Gaming Tuning. The 'Settings' tab is active, showing the 'Auto run at Windows Startup' option.

Auto run at Windows Startup

**Description**  
Configure ASRock Phantom Gaming

Version : 3.0.230

### 3.3 ASRock Live Update & APP Shop

The ASRock Live Update & APP Shop is an online store for purchasing and downloading software applications for your ASRock computer. You can quickly and easily install various apps and support utilities. With ASRock Live Update & APP Shop, you can optimize your system and keep your motherboard up to date simply with a few clicks.

Double-click  on your desktop to access ASRock Live Update & APP Shop utility.

*\*You need to be connected to the Internet to download apps from the ASRock Live Update & APP Shop.*

#### 3.3.1 UI Overview

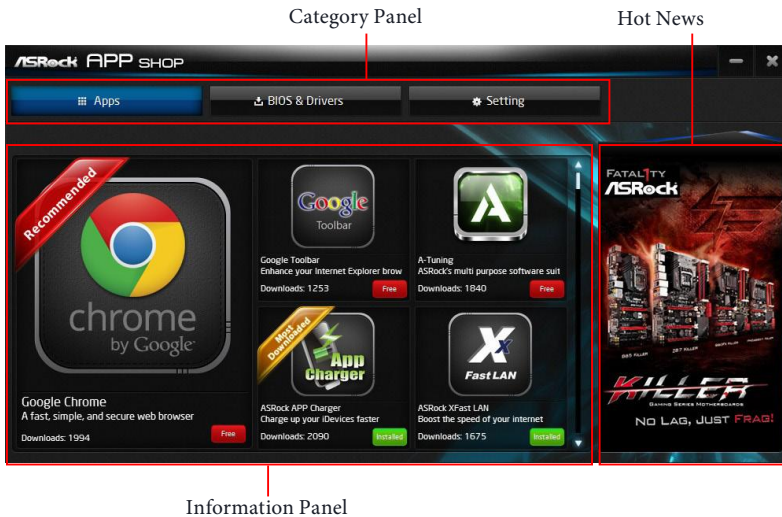

**Category Panel:** The category panel contains several category tabs or buttons that when selected the information panel below displays the relative information.

**Information Panel:** The information panel in the center displays data about the currently selected category and allows users to perform job-related tasks.

**Hot News:** The hot news section displays the various latest news. Click on the image to visit the website of the selected news and know more.

## 3.3.2 Apps

When the "Apps" tab is selected, you will see all the available apps on screen for you to download.

### Installing an App

#### Step 1

Find the app you want to install.



The most recommended app appears on the left side of the screen. The other various apps are shown on the right. Please scroll up and down to see more apps listed.

You can check the price of the app and whether you have already installed it or not.

 - The red icon displays the price or "Free" if the app is free of charge.

 - The green "Installed" icon means the app is installed on your computer.

#### Step 2

Click on the app icon to see more details about the selected app.

### Step 3

If you want to install the app, click on the red icon  to start downloading.



### Step 4

When installation completes, you can find the green "Installed" icon appears on the upper right corner.

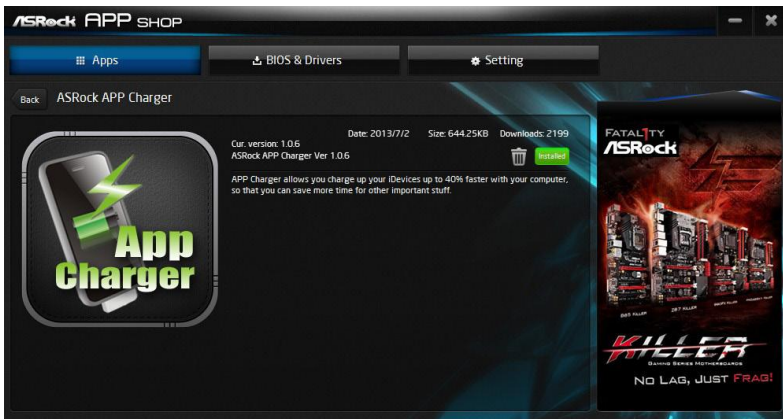

To uninstall it, simply click on the trash can icon .

\*The trash icon may not appear for certain apps.

## Upgrading an App

You can only upgrade the apps you have already installed. When there is an available new version for your app, you will find the mark of "New Version" appears below the installed app icon.



### Step 1

Click on the app icon to see more details.

### Step 2

Click on the yellow icon  to start upgrading.

### 3.3.3 BIOS & Drivers

#### Installing BIOS or Drivers

When the "BIOS & Drivers" tab is selected, you will see a list of recommended or critical updates for the BIOS or drivers. Please update them all soon.

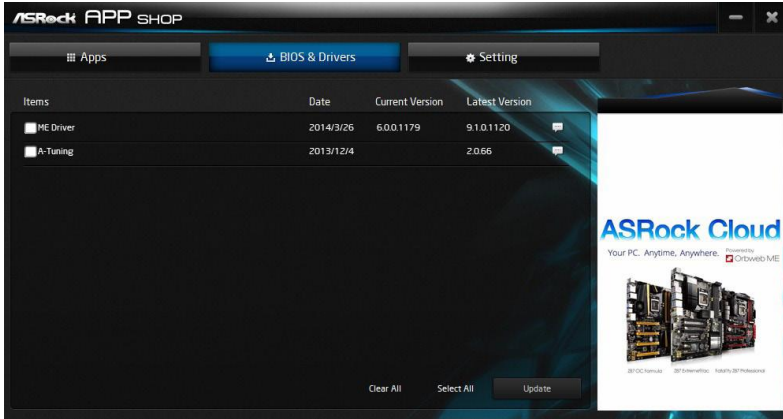

#### Step 1

Please check the item information before update. Click on to see more details.

#### Step 2

Click to select one or more items you want to update.

#### Step 3

Click Update to start the update process.

### 3.3.4 Setting

In the "Setting" page, you can change the language, select the server location, and determine if you want to automatically run the ASRock Live Update & APP Shop on Windows startup.

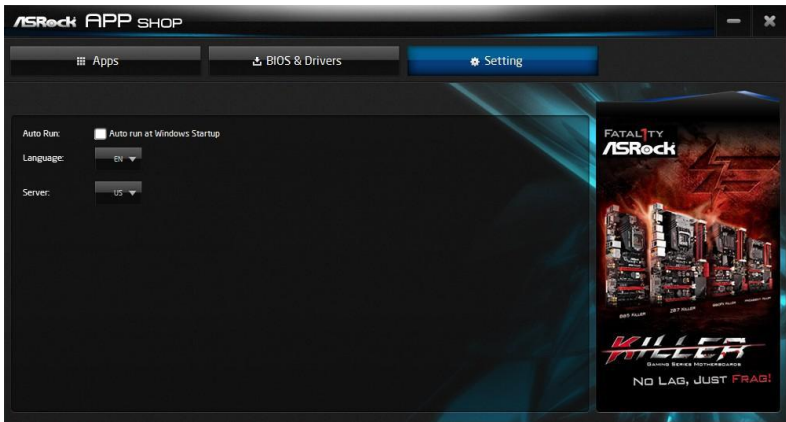

### 3.4 Nahimic Audio

Nahimic audio software provides an incredible high definition sound technology which boosts the audio and voice performance of your system. Nahimic Audio interface is composed of four tabs: Audio, Microphone, Sound Tracker and Settings.

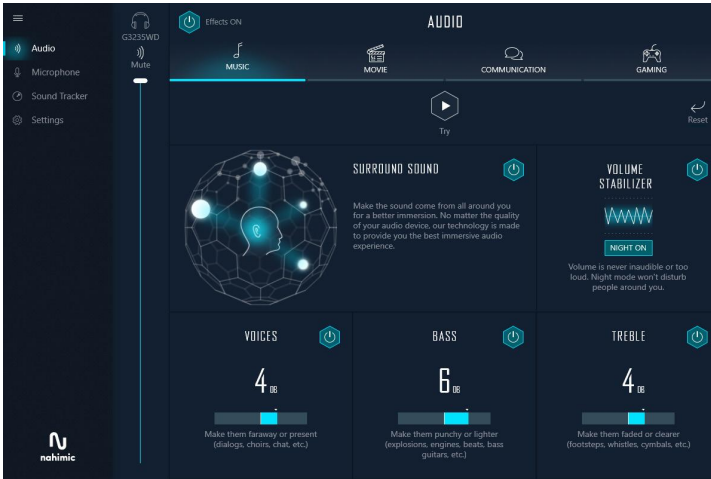

There are four functions in Nahimic audio :

No.	Function	Description
1	Audio	From this tab, you can mute the current audio device, choose between four factory audio profiles, turn all audio effects on/off, restores the current profile to its default settings and access Surround Sound and various features.
2	Microphone	From this tab, you can mute the current mic device, choose between two factory mic profiles, turn/off all microphone effects, restore the current profile to its default settings, and access Static Noise Suppression and various features.
3	Sound Tracker	The Sound Tracker provides a visual indication localizing the sources of the sounds while in a game. These are represented by dynamic segments pointing the direction of the sounds: the more opaque they are, the stronger the sounds are.
4	Settings	From this tab, you can access all settings and information of the software.

### 3.5 ASRock Polychrome SYNC

ASRock Polychrome SYNC is a lighting control utility specifically designed for unique individuals with sophisticated tastes to build their own stylish colorful lighting system. Simply by connecting the LED strip, you can customize various lighting schemes and patterns, including Static, Breathing, Strobe, Cycling, Music, Wave and more.

#### Connecting the LED Strip

Connect your RGB LED strips to the **RGB LED Headers (RGB\_LED1 / RGB\_LED2)** on the motherboard.

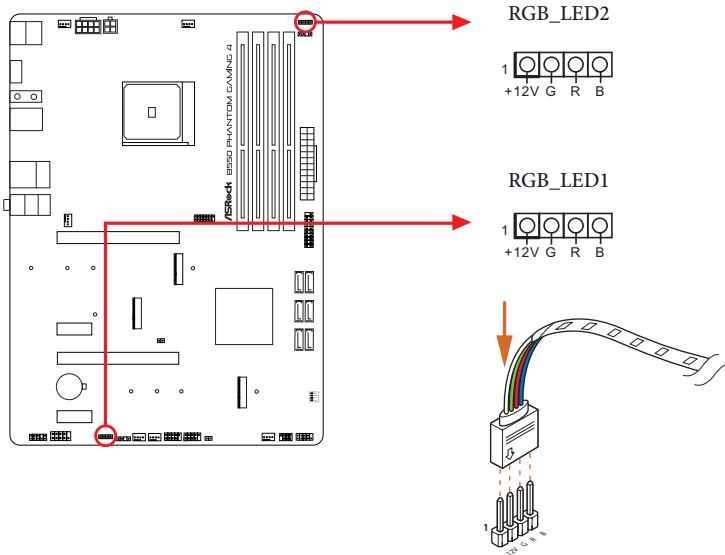

1. Never install the RGB LED cable in the wrong orientation; otherwise, the cable may be damaged.
2. Before installing or removing your RGB LED cable, please power off your system and unplug the power cord from the power supply. Failure to do so may cause damages to motherboard components.



1. Please note that the RGB LED strips do not come with the package.
2. The RGB LED header supports standard 5050 RGB LED strip (12V/G/R/B), with a maximum power rating of 3A (12V) and length within 2 meters.

## Connecting the Addressable RGB LED Strip

Connect your Addressable RGB LED strips to the **Addressable LED Headers (ADDR\_LED1 / ADDR\_LED2)** on the motherboard.

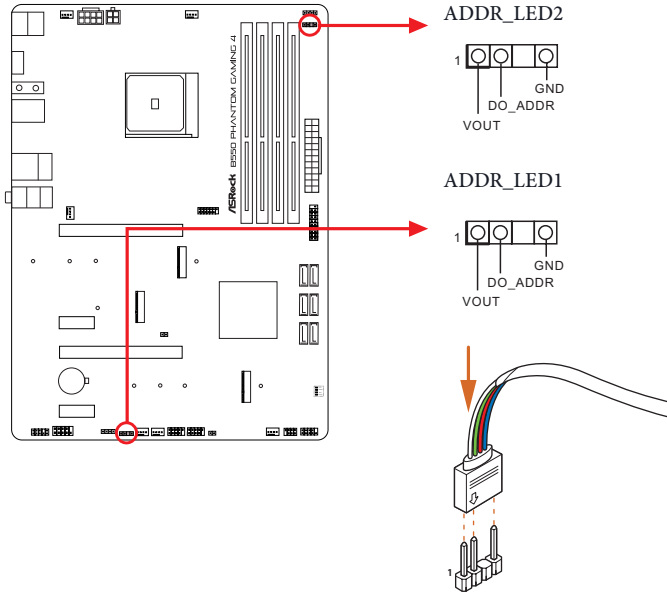

1. Never install the RGB LED cable in the wrong orientation; otherwise, the cable may be damaged.
2. Before installing or removing your RGB LED cable, please power off your system and unplug the power cord from the power supply. Failure to do so may cause damages to motherboard components.



1. Please note that the RGB LED strips do not come with the package.
2. The RGB LED header supports WS2812B addressable RGB LED strip (5V/Data/GND), with a maximum power rating of 3A (5V) and length within 2 meters.

## ASRock Polychrome SYNC Utility

Now you can adjust the RGB LED color through the ASRock Polychrome SYNC Utility. Download this utility from the ASRock Live Update & APP Shop and start coloring your PC style your way!

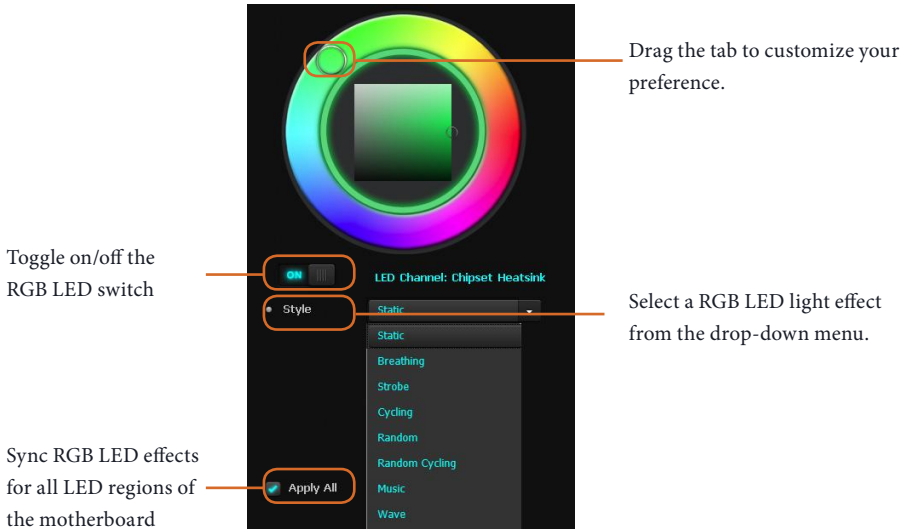

## Chapter 4 UEFI SETUP UTILITY

### 4.1 Introduction

This section explains how to use the UEFI SETUP UTILITY to configure your system. You may run the UEFI SETUP UTILITY by pressing <F2> or <Del> right after you power on the computer, otherwise, the Power-On-Self-Test (POST) will continue with its test routines. If you wish to enter the UEFI SETUP UTILITY after POST, restart the system by pressing <Ctl> + <Alt> + <Delete>, or by pressing the reset button on the system chassis. You may also restart by turning the system off and then back on.



*Because the UEFI software is constantly being updated, the following UEFI setup screens and descriptions are for reference purpose only, and they may not exactly match what you see on your screen.*

#### 4.1.1 UEFI Menu Bar

The top of the screen has a menu bar with the following selections:

**Main** For setting system time/date information

**OC Tweaker** For overclocking configurations

**Advanced** For advanced system configurations

**Tool** Useful tools

**H/W Monitor** Displays current hardware status

**Security** For security settings

**Boot** For configuring boot settings and boot priority

**Exit** Exit the current screen or the UEFI Setup Utility

## 4.1.2 Navigation Keys

Use <←> key or <→> key to choose among the selections on the menu bar, and use <↑> key or <↓> key to move the cursor up or down to select items, then press <Enter> to get into the sub screen. You can also use the mouse to click your required item.

Please check the following table for the descriptions of each navigation key.

Navigation Key(s)	Description
+ / -	To change option for the selected items
<Tab>	Switch to next function
<PGUP>	Go to the previous page
<PGDN>	Go to the next page
<HOME>	Go to the top of the screen
<END>	Go to the bottom of the screen
<F1>	To display the General Help Screen
<F7>	Discard changes and exit the SETUP UTILITY
<F9>	Load optimal default values for all the settings
<F10>	Save changes and exit the SETUP UTILITY
<F12>	Print screen
<ESC>	Jump to the Exit Screen or exit the current screen

## 4.2 Main Screen

When you enter the UEFI SETUP UTILITY, the Main screen will appear and display the system overview.

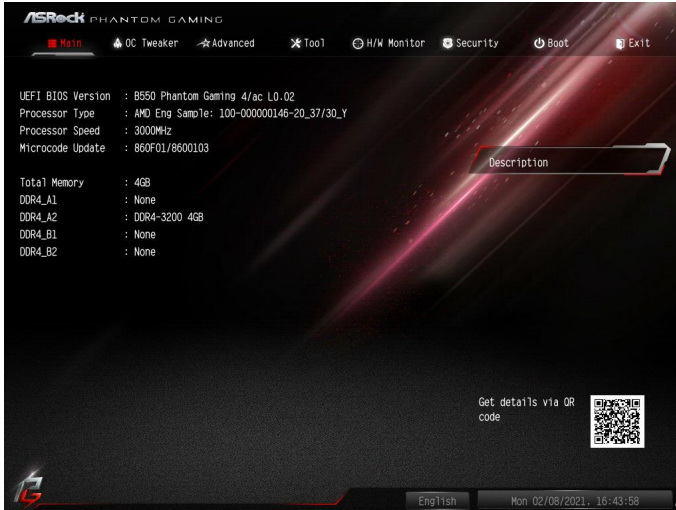

## 4.3 OC Tweaker Screen

In the OC Tweaker screen, you can set up overclocking features.



*Because the UEFI software is constantly being updated, the following UEFI setup screens and descriptions are for reference purpose only, and they may not exactly match what you see on your screen.*

### Overclock Mode(Bus Speed)

Select the overclock mode. Warning! When overlocking also the PCIe, PCI, SATA and USB busses will be overlocked which may cause instability or failure. Please install an operating system and the drivers required before overlocking, or else your HDD's may be undetectable. Overlocking is not supported if the monitor is connected via the onboard D-Bus/VGA connector.

### CPU Frequency and Voltage(VID) Change

If this item is set to [Manual], the multiplier and voltage will be set based on user selection. Final result is depending on the CPU's capability.

### CPU Core (Per CCX)

### CPU Voltage

Specifies a custom CPU core voltage (mV), Should be combined with a custom CPU core

frequency. Power saving features for idle cores (e.g. cc6 sleep) remain active.

## CCD0

### CCX0 Frequency (MHz)

Use this item to adjust CCX0 Frequency.

### CCX1 Frequency (MHz)

Use this item to adjust CCX1 Frequency.

## CCD1

### CCX0 Frequency (MHz)

Use this item to adjust CCX0 Frequency.

### CCX1 Frequency (MHz)

Use this item to adjust CCX1 Frequency.

## SoC/Uncore OC Voltage(VID)

Specify the SoC/Uncore voltage (VDD\_SOC) in mV to support memory and Infinity Fabric overlocking. VDD\_SOC also determines the GPU voltage on processors with integrated graphics. "SoC/Uncore OC Mode" needs to be enabled to force this voltage.

## CLD0 VDDP Voltage Control

AMD Overclocking Setup VDDP is a voltage for the DDR4 bus signaling (PHY), and it is derived from your DRAM Voltage (VDDIO\_Mem). As a result, VDDP voltage in mV can approach but not exceed your DRAM Voltage.

## CLD0 VDDG CCD Voltage Control

AMD Overclocking Setup VDDG CCD represents voltage for the data portion of the Infinity Fabric. It is derived from the CPU SoC/Uncore Voltage (VDD\_SOC). VDDG can approach but not exceed VDD\_SOC.

## CLD0 VDDG IOD Voltage Control

AMD Overclocking Setup VDDG IOD represents voltage for the data portion of the Infinity Fabric. It is derived from the CPU SoC/Uncore Voltage (VDD\_SOC). VDDG can approach but not exceed VDD\_SOC.

## DRAM Information

### DRAM Frequency

If [Auto] is selected, the motherboard will detect the memory module(s) inserted and assign the appropriate frequency automatically. Setting DRAM Frequency can adjust DRAM Timing.

### DRAM Voltage

Configure the voltage for the DRAM Voltage.

### Infinity Fabric Frequency and Dividers

AMD Overclocking Setup Set Infinity Fabric frequency (FCLK). Auto: FCLK = MCLK. Manual: FCLK must be less than or equal to MCLK for best performance in most cases. Latency penalties are incurred if FCLK and MCLK are mismatched, but sufficiently high MCLK can negate or overcome this penalty.

## DRAM Timing Configuration

### External Voltage Settings and Load-line Calibration

#### CPU Vcore Voltage

Input voltage for the processor by the external voltage regulator.

#### CPU Load-Line Calibration

CPU Load-Line Calibration helps prevent CPU voltage droop when the system is under heavy loading.

#### VDDCR\_SOC Voltage

Input voltage for the processor by the external voltage regulator.

#### VDDCR\_SOC Load-Line Calibration

VDDCR\_SOC Load-Line Calibration helps prevent VDDCR\_SOC voltage droop when the system is under heavy loading.

#### VPPM

Configure the voltage for the VPPM.

#### 2.50V Voltage

Configure the voltage for the 2.50V PROM Voltage.

#### +1.8V Voltage

Configure the voltage for the +1.8V Voltage. The default value is [Auto].

## VDDP

Configure the voltage for the VDDP.

## Chipset 1.05V Voltage

Configure the voltage for the Chipset 1.05V Voltage.

## Save User Default

Type a profile name and press enter to save your settings as user default.

## Load User Default

Load previously saved user defaults.

## Save User UEFI Setup Profile to Disk

It helps you to save current UEFI settings as an user profile to disk.

## Load User UEFI Setup Profile from Disk

You can load previous saved profile from the disk.

## 4.4 Advanced Screen

In this section, you may set the configurations for the following items: CPU Configuration, Onboard Devices Configuration, Storage Configuration, ACPI Configuration, Trusted Computing, AMD CBS, AMD PBS and AMD Overclocking.

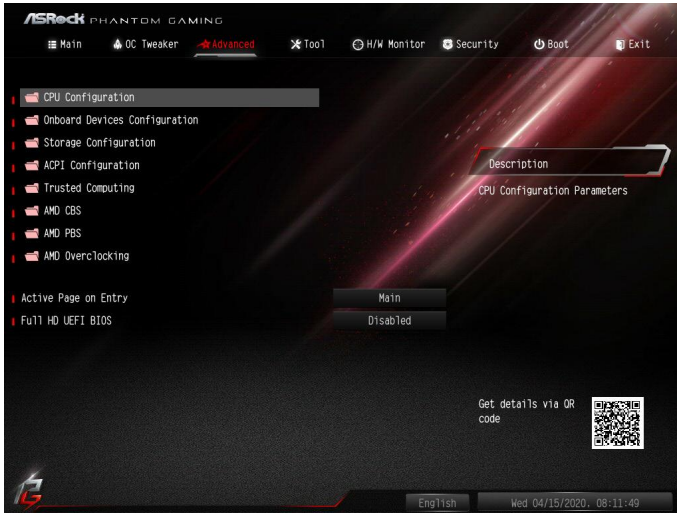

*Setting wrong values in this section may cause the system to malfunction.*

### UEFI Configuration

#### Active Page on Entry

Select the default page when entering the UEFI setup utility.

#### Full HD UEFI

When [Auto] is selected, the resolution will be set to 1920 x 1080 if the monitor supports Full HD resolution. If the monitor does not support Full HD resolution, then the resolution will be set to 1024 x 768. When [Disable] is selected, the resolution will be set to 1024 x 768 directly.

## 4.4.1 CPU Configuration

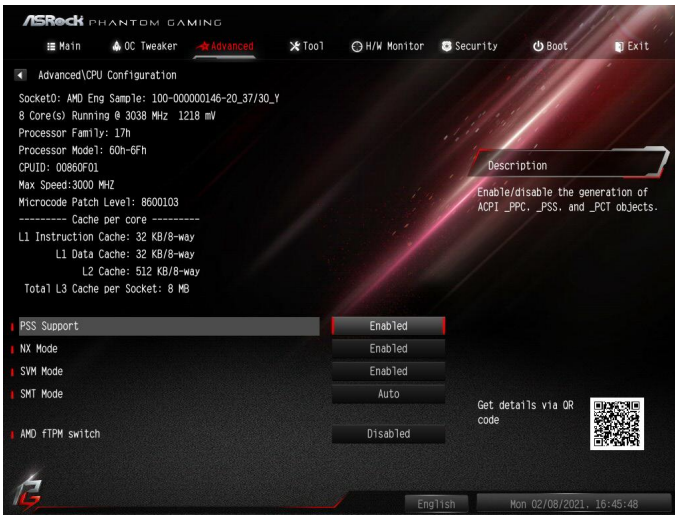

### PSS Support

Use this to enable or disable the generation of ACPI\_PPC, \_PSS, and \_PCT objects.

### NX Mode

Use this to enable or disable NX mode.

### SVM Mode

When this is set to [Enabled], a VMM (Virtual Machine Architecture) can utilize the additional hardware capabilities provided by AMD-V. The default value is [Enabled]. Configuration options: [Enabled] and [Disabled].

### SMT Mode

This item can be used to disable symmetric multithreading. To re-enable SMT, a power cycle is needed after selecting [Auto].

Warning: S3 is not supported on systems where SMT is disabled.

### AMD fTPM Switch

Use this to enable or disable AMD CPU fTPM.

## 4.4.2 Onboard Devices Configuration

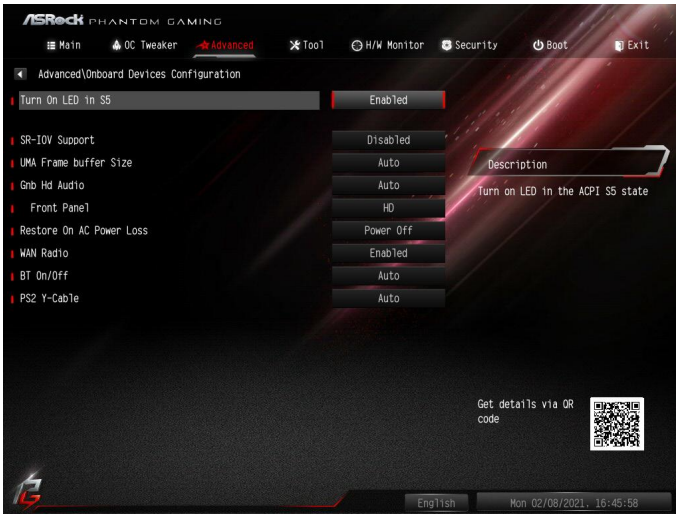

### Turn On LED in S5

Turn on LED in the ACPI S5 state.

### SR-IOV Support

Enable/disable the SR-IOV (Single Root IO Virtualization Support) if the system has SR-IOV capable PCIe devices.

### UMA Frame buffer Size (Only for processor with integrated graphics)

This item allows you to set the size of the UMA frame buffer.

### Gnb Hd Audio

Enable/disable onboard HD audio. Set to Auto to enable onboard HD audio and automatically disable it when a sound card is installed.

### Front Panel

Enable/disable front panel HD audio.

### Restore on AC/Power Loss

Select the power state after a power failure. If [Power Off] is selected, the power will remain off when the power recovers. If [Power On] is selected, the system will start to boot up when the power recovers.

## WAN Radio

Configure the WiFi module's connectivity.

## BT On/Off

Enable/disable the bluetooth.

## PS2 Y-Cable

Enable the PS2 Y-Cable or set this option to Auto.

## 4.4.3 Storage Configuration

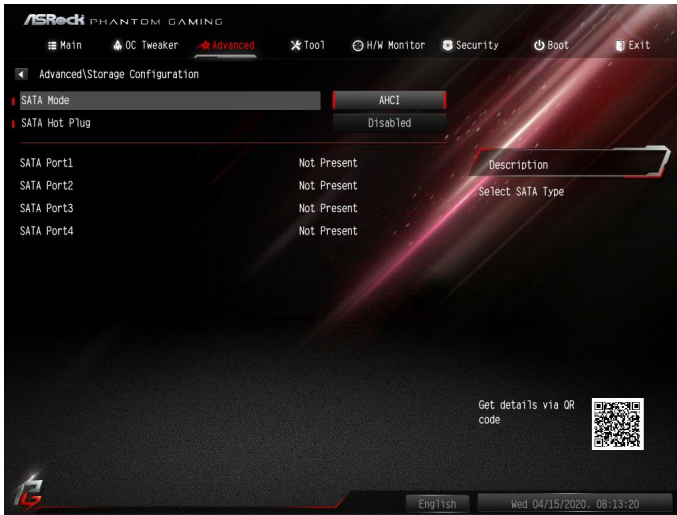

### SATA Mode

AHCI: Supports new features that improve performance.

RAID: Combine multiple disk drives into a logical unit.

### SATA Hot Plug

Enable/disable the SATA Hot Plug function.

## 4.4.4 ACPI Configuration

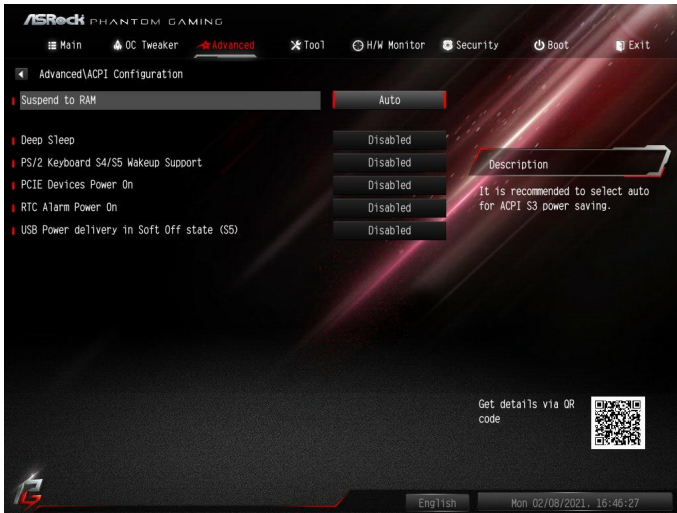

### Suspend to RAM

It is recommended to select auto for ACPI S3 power saving.

### Deep Sleep

Configure deep sleep mode for power saving when the computer is shut down.

### PS/2 Keyboard S4/S5 Wakeup Support

Allow the system to be waked up by a PS/2 Keyboard in S4/S5.

### USB Keyboard/Mouse Power On (For B550 Phantom Gaming 4/ac)

Allow the system to be waked up by an USB Keyboard/Mouse device.

### PCIE Devices Power On

Allow the system to be waked up by a PCIE device and enable wake on LAN.

### RTC Alarm Power On

Allow the system to be waked up by the real time clock alarm. Set it to By OS to let it be handled by your operating system.

### USB Power Delivery in Soft Off State (S5)

If this option is enabled, the USB port will provide power to your devices even when the system is in Power State S5.

## 4.4.5 Trusted Computing

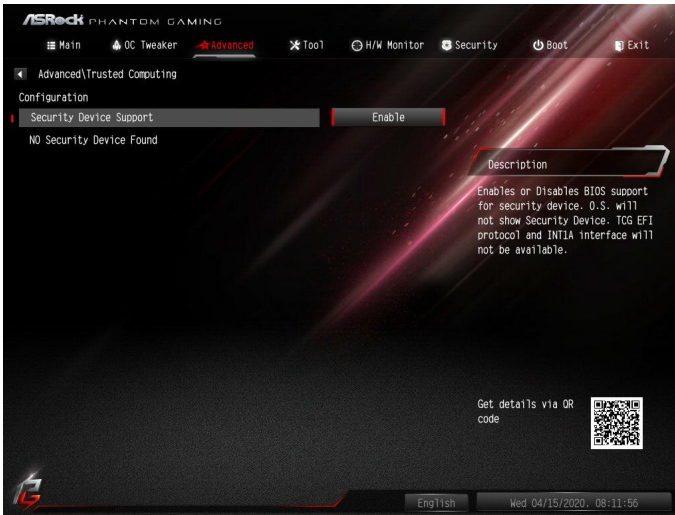

### Security Device Support

Enable or disable BIOS support for security device.

## 4.4.6 AMD CBS

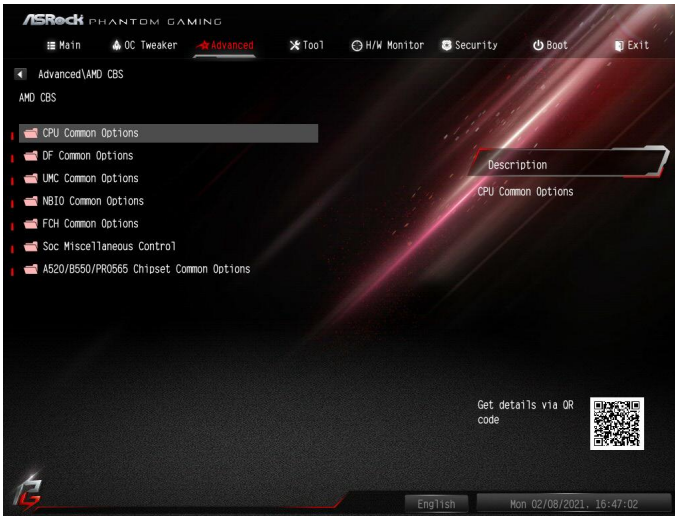

The AMD CBS menu accesses AMD specific features.

## 4.4.7 AMD PBS



The AMD PBS menu accesses AMD specific features.

## 4.4.8 AMD Overclocking

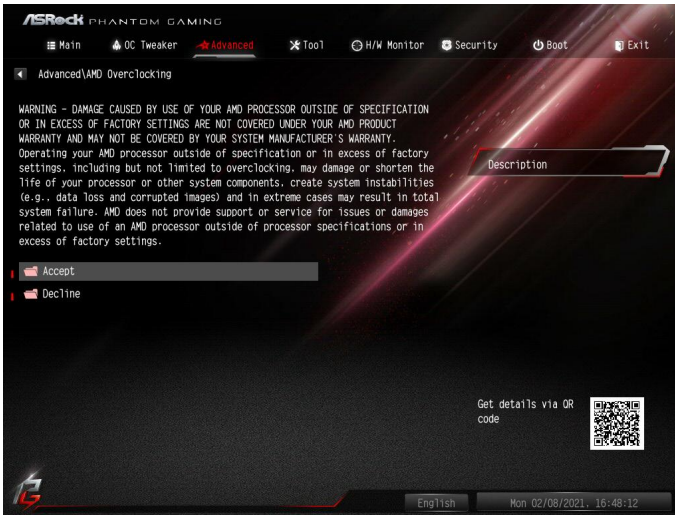

The AMD Overclocking menu accesses options for configuring CPU frequency and voltage.

## 4.5 Tools

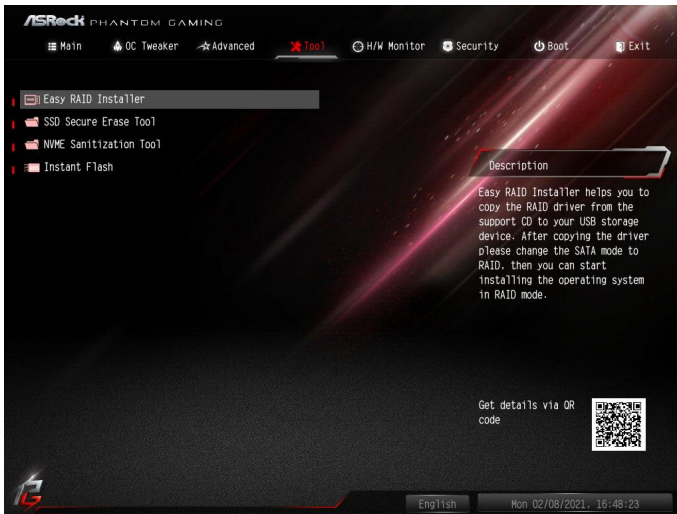

### Easy RAID Installer

Easy RAID Installer helps you to copy the RAID driver from the support CD to your USB storage device. After copying the drivers please change the SATA mode to RAID, then you can start installing the operating system in RAID mode.

### SSD Secure Erase Tool

Use this tool to securely erase SSD.

### NVME Sanitization Tool

After you sanitize SSD, all user data will be permanently destroyed on the SSD and cannot be recovered.

### Instant Flash

Save UEFI files in your USB storage device and run Instant Flash to update your UEFI.

## 4.6 Hardware Health Event Monitoring Screen

This section allows you to monitor the status of the hardware on your system, including the parameters of the CPU temperature, motherboard temperature, fan speed and voltage.



### CPU FAN1 Setting

Select a fan mode for CPU Fan 1, or choose Customize to set 5 CPU temperatures and assign a respective fan speed for each temperature.

### CPU FAN1 Temp Source

Select a fan temperature source for CPU Fan 1.

### FAN Configuration

#### CPU\_FAN2/WP Switch

Select CPU Water Pump mode.

#### CPU Fan 2 Control Mode

Select PWM mode or DC mode for CPU Fan 2 .

### CPU Fan 2 Setting

Select a fan mode for CPU Fan 2, or choose Customize to set 5 CPU temperatures and assign a respective fan speed for each temperature.

## CPU Fan 2 Temp Source

Select a fan temperature source for CPU Fan 2.

## CHA\_FAN1/WP Switch

Select CHA\_FAN1 or Water Pump mode.

## Chassis Fan 1 Control Mode

Select PWM mode or DC mode for Chassis Fan 1 .

## Chassis Fan 1 Setting

Select a fan mode for Chassis Fan 1, or choose Customize to set 5 CPU temperatures and assign a respective fan speed for each temperature.

## Chassis Fan 1 Temp Source

Select a fan temperature source for Chassis Fan 1.

## CHA\_FAN2/WP Switch

Select CHA\_FAN2 or Water Pump mode.

## Chassis Fan 2 Control Mode

Select PWM mode or DC mode for Chassis Fan 2 .

## Chassis Fan 2 Setting

Select a fan mode for Chassis Fan 2, or choose Customize to set 5 CPU temperatures and assign a respective fan speed for each temperature.

## Chassis Fan 2 Temp Source

Select a fan temperature source for Chassis Fan 2.

## CHA\_FAN3/WP Switch

Select CHA\_FAN3 or Water Pump mode.

## Chassis Fan 3 Control Mode

Select PWM mode or DC mode for Chassis Fan 3 .

## Chassis Fan 3 Setting

Select a fan mode for Chassis Fan 3, or choose Customize to set 5 CPU temperatures and assign a respective fan speed for each temperature.

### Chassis Fan 3 Temp Source

Select a fan temperature source for Chassis Fan 3.

### CHA\_FAN4/WP Switch

Select CHA\_FAN4 or Water Pump mode.

### Chassis Fan 4 Control Mode

Select PWM mode or DC mode for Chassis Fan 4.

### Chassis Fan 4 Setting

Select a fan mode for Chassis Fan 3, or choose Customize to set 5 CPU temperatures and assign a respective fan speed for each temperature.

### Chassis Fan 4 Temp Source

Select a fan temperature source for Chassis Fan 4.

### Fan-Tastic

Select a fan mode for Fan, or choose Customize to set 5 CPU temperatures and assign a respective fan speed for each temperature.

### FanTuning

Detect the lowest fan speed in the system. It may take 3-5 minutes to complete.

## 4.7 Security Screen

In this section you may set or change the supervisor/user password for the system. You may also clear the user password.

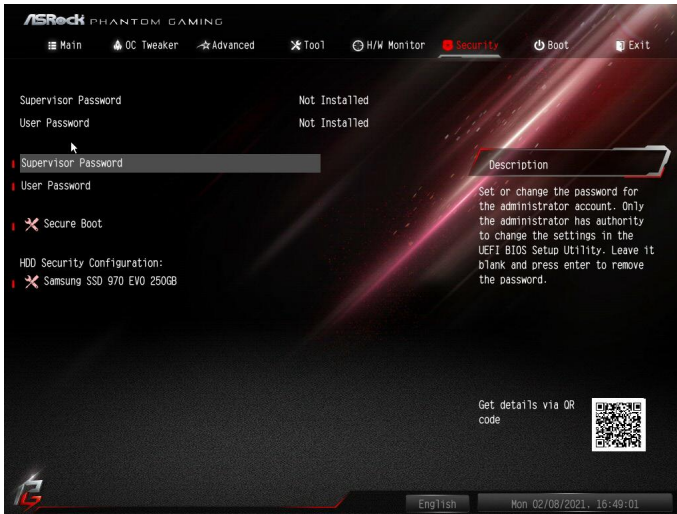

### Supervisor Password

Set or change the password for the administrator account. Only the administrator has authority to change the settings in the UEFI Setup Utility. Leave it blank and press enter to remove the password.

### User Password

Set or change the password for the user account. Users are unable to change the settings in the UEFI Setup Utility. Leave it blank and press enter to remove the password.

### Secure Boot

Enable to support Secure Boot.

## 4.8 Boot Screen

This section displays the available devices on your system for you to configure the boot settings and the boot priority.

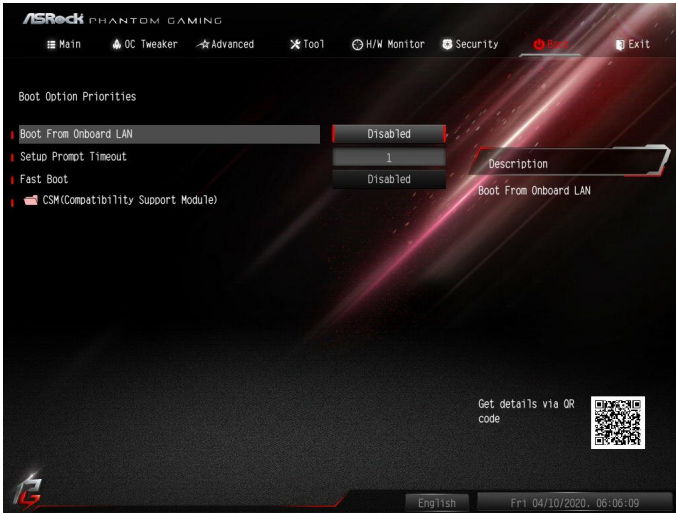

### Boot From Onboard LAN

Allow the system to be waked up by the onboard LAN.

### Setup Prompt Timeout

Configure the number of seconds to wait for the setup hot key.

### Fast Boot

Fast Boot minimizes your computer's boot time. In fast mode you may not boot from an USB storage device.

## CSM (Compatibility Support Module)

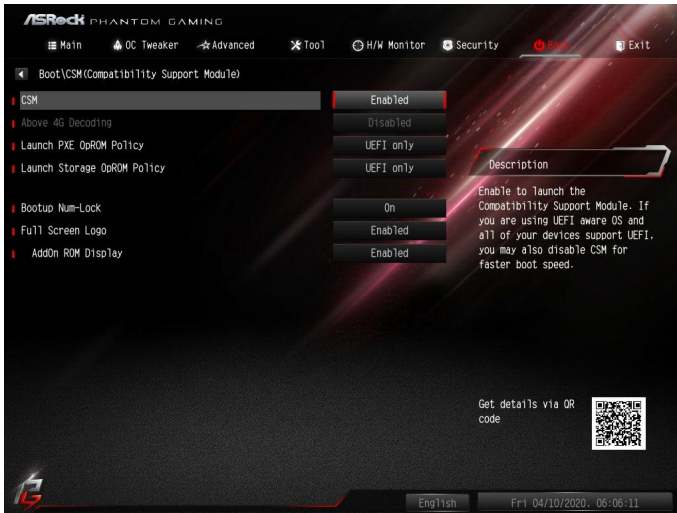

### CSM

Enable to launch the Compatibility Support Module. Please do not disable unless you're running a WHCK test.

### Above 4G Decoding

Enable or disable 64bit capable Devices to be decoded in Above 4G Address Space (only if the system supports 64 bit PCI decoding).

### Launch PXE OpROM Policy

Select UEFI only to run those that support UEFI option ROM only. Select Legacy only to run those that support legacy option ROM only. Select Do not launch to not execute both legacy and UEFI option ROM.

### Launch Storage OpROM Policy

Select UEFI only to run those that support UEFI option ROM only. Select Legacy only to run those that support legacy option ROM only. Select Do not launch to not execute both legacy and UEFI option ROM.

### Bootup Num-Lock

Select whether Num Lock should be turned on or off when the system boots up.

## Full Screen Logo

Enable to display the boot logo or disable to show normal POST messages.

## AddOn ROM Display

Enable AddOn ROM Display to see the AddOn ROM messages or configure the AddOn ROM if you've enabled Full Screen Logo. Disable for faster boot speed.

## 4.9 Exit Screen

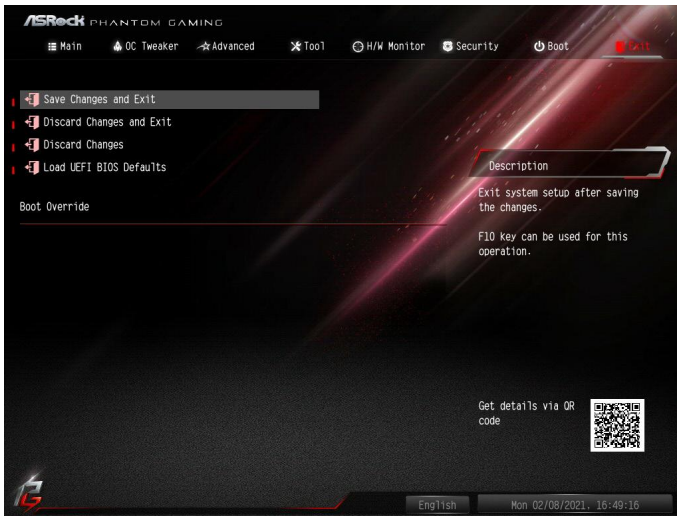

### Save Changes and Exit

When you select this option the following message, “Save configuration changes and exit setup?” will pop out. Select [OK] to save changes and exit the UEFI SETUP UTILITY.

### Discard Changes and Exit

When you select this option the following message, “Discard changes and exit setup?” will pop out. Select [OK] to exit the UEFI SETUP UTILITY without saving any changes.

### Discard Changes

When you select this option the following message, “Discard changes?” will pop out. Select [OK] to discard all changes.

### Load UEFI BIOS Defaults

Load UEFI BIOS Default values for all the setup questions. The F9 key can be used for this operation.

Version 1.1

Published April 2023

Copyright©2023 ASRock INC. All rights reserved.

## Copyright Notice:

No part of this documentation may be reproduced, transcribed, transmitted, or translated in any language, in any form or by any means, except duplication of documentation by the purchaser for backup purpose, without written consent of ASRock Inc.

Products and corporate names appearing in this documentation may or may not be registered trademarks or copyrights of their respective companies, and are used only for identification or explanation and to the owners' benefit, without intent to infringe.

## Disclaimer:

Specifications and information contained in this documentation are furnished for informational use only and subject to change without notice, and should not be constructed as a commitment by ASRock. ASRock assumes no responsibility for any errors or omissions that may appear in this documentation.

With respect to the contents of this documentation, ASRock does not provide warranty of any kind, either expressed or implied, including but not limited to the implied warranties or conditions of merchantability or fitness for a particular purpose.

In no event shall ASRock, its directors, officers, employees, or agents be liable for any indirect, special, incidental, or consequential damages (including damages for loss of profits, loss of business, loss of data, interruption of business and the like), even if ASRock has been advised of the possibility of such damages arising from any defect or error in the documentation or product.



This device complies with Part 15 of the FCC Rules. Operation is subject to the following two conditions:

- (1) this device may not cause harmful interference, and
- (2) this device must accept any interference received, including interference that may cause undesired operation.

This equipment has been tested and found to comply with the limits for a Class B digital device, pursuant to part 15 of the FCC Rules. These limits are designed to provide reasonable protection against harmful interference in a residential installation. This equipment generates, uses and can radiate radio frequency energy and, if not installed and used in accordance with the instructions, may cause harmful interference to radio communications. However, there is no guarantee that interference will not occur in a particular installation. If this equipment does cause harmful interference to radio or television reception, which can be determined by turning the equipment off and on, the user is encouraged to try to correct the interference by one or more of the following measures:

- Reorient or relocate the receiving antenna.
- Increase the separation between the equipment and receiver.
- Connect the equipment into an outlet on a circuit different from that to which the receiver is connected.
- Consult the dealer or an experienced radio/TV technician for help.

The terms HDMI® and HDMI High-Definition Multimedia Interface, and the HDMI logo are trademarks or registered trademarks of HDMI Licensing LLC in the United States and other countries.



#### WARNING

THIS PRODUCT CONTAINS A BUTTOON BATTERY  
If swallowed, a button battery can cause serious injury or death.  
Please keep batteries out of sight or reach of children.

#### CALIFORNIA, USA ONLY

The Lithium battery adopted on this motherboard contains Perchlorate, a toxic substance controlled in Perchlorate Best Management Practices (BMP) regulations passed by the California Legislature. When you discard the Lithium battery in California, USA, please follow the related regulations in advance.

“Perchlorate Material-special handling may apply, see [www.dtsc.ca.gov/hazardouswaste/perchlorate](http://www.dtsc.ca.gov/hazardouswaste/perchlorate)”

#### AUSTRALIA ONLY

Our goods come with guarantees that cannot be excluded under the Australian Consumer Law. You are entitled to a replacement or refund for a major failure and compensation for any other reasonably foreseeable loss or damage caused by our goods. You are also entitled to have the goods repaired or replaced if the goods fail to be of acceptable quality and the failure does not amount to a major failure. If you require assistance please call ASRock Tel : +886-2-28965588 ext.123 (Standard International call charges apply)



ASRock INC. hereby declares that this device is in compliance with the essential requirements and other relevant provisions of related UKCA Directives. Full text of UKCA declaration of conformity is available at: <http://www.asrock.com>



ASRock INC. hereby declares that this device is in compliance with the essential requirements and other relevant provisions of related Directives. Full text of EU declaration of conformity is available at: <http://www.asrock.com>

ASRock follows the green design concept to design and manufacture our products, and makes sure that each stage of the product life cycle of ASRock product is in line with global environmental regulations. In addition, ASRock disclose the relevant information based on regulation requirements.

Please refer to <https://www.asrock.com/general/about.asp?cat=Responsibility> for information disclosure based on regulation requirements ASRock is complied with.



DO NOT throw the motherboard in municipal waste. This product has been designed to enable proper reuse of parts and recycling. This symbol of the crossed out wheeled bin indicates that the product (electrical and electronic equipment) should not be placed in municipal waste. Check local regulations for disposal of electronic products.

## CE Warning

This device complies with directive 2014/53/EU issued by the Commission of the European Community.

This equipment complies with EU radiation exposure limits set forth for an uncontrolled environment.

This equipment should be installed and operated with minimum distance 20cm between the radiator & your body.

Operations in the 5.15-5.35GHz band are restricted to indoor usage only.

	AT	BE	BG	CH	CY	CZ	DE
	DK	EE	EL	ES	FI	FR	HR
	HU	IE	IS	IT	LI	LT	LU
	LV	MT	NL	NO	PL	PT	RO
	SE	SI	SK	TR			



Radio transmit power per transceiver type

Function	Frequency	Maximum Output Power (EIRP)
WiFi	2400-2483.5 MHz	18.5 + / -1.5 dbm
	5150-5250 MHz	21.5 + / -1.5 dbm
	5250-5350 MHz	18.5 + / -1.5 dbm (no TPC)
		21.5 + / -1.5 dbm (TPC)
Bluetooth	5470-5725 MHz	25.5 + / -1.5 dbm (no TPC)
		28.5 + / -1.5 dbm (TPC)
	2400-2483.5 MHz	8.5 + / -1.5 dbm

**ASRock Incorporation**

**Contains Wi-Fi module with Bluetooth**

**Intel® Wi-Fi 3168**

**Model: 3168NGW**

FCC ID: PD93168NG



IC: 1000M-3168NG

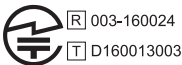

5.15~5.35GHz indoor use only